



FAIRHAVEN

BBQ Gazebo

ASSEMBLY GUIDE



THANK YOU FOR PURCHASING OUR FAIRHAVEN BBQ GAZEBO



This manual will provide you with clear and detailed instructions on how to safely and correctly assemble and maintain your gazebo, to ensure it brings you many years of use and enjoyment.

IMPORTANT: RETAIN FOR FUTURE REFERENCE: READ CAREFULLY

Warning: Important safety instructions. It is important for the safety of persons to follow these instructions. Please keep these instructions in a safe place.

This product can be used by children ages from 8 years and above and persons with reduced physical, sensory or mental capabilities or lack of experience and knowledge if they have been given supervision or instruction concerning use of the product in a safe way and understand the hazards involved. Children shall not play with the product. Cleaning and user maintenance shall not be conducted by children without supervision of an adult.

Intended use

This gazebo is intended for outdoor domestic use in residential environments, and to protect users from direct sunlight, glare and heat. Any use or modification to the gazebo not included in this manual shall be considered as improper use, which may cause considerable danger to users and property and will void the product warranty.

Attention: The schematics in this manual are for assembly and operation illustration only. They may differ from the gazebos actual appearance.

⚠ WARNING

- When assembling and using this product, safety precautions should always be followed to reduce the risk of personal injury and damage to equipment. Please read all instructions before assembly and use.
- At least two or more people are recommended for safe assembly.
- Keep all children and pets away from assembly area.
- Check all nuts and bolts for tightness before and during usage.
- Non permanent structure. Do not use in extreme weather conditions including heavy rain or high winds.
- Do not leave the gazebo unattended. Louvres must remain in the open position when not in use.
- Do not place the product near an open flame; or too close to any heat source.

EN TABLE OF CONTENTS

DE INHALTSVERZEICHNIS

FR TABLE DES MATIÈRES

NL INHOUDSOPGAVE

04

EN- Before Assembling Your Gazebo

DE- Vor dem Zusammenbau Ihrer Pergola

FR- Avant d'assembler votre pergola

NL- Voordat u uw pergola monteert

08

EN- Important Safety Advice

DE- Wichtige Sicherheitshinweise

FR- Conseils de sécurité importants

NL- Belangrijk veiligheidsadvies

13

EN- List of Parts

DE- Liste der Teile

FR- Liste des pièces

NL- Onderdelenlijst

20

EN- Assembly

43

EN- Operating Your Gazebo

DE- Betrieb Ihrer Pergola

FR- Fonctionnement de votre pergola

NL- Gebruik van uw pergola

44

EN- Problem Solving

DE- Problemlösung

FR- Résolution de problèmes

NL- Probleemoplossing

46

EN- Care & Maintenance

DE- Pflege und Wartung

FR- Entretien et maintenance

NL- Verzorging en onderhoud

48

EN- Product Warranty & Limitation Of Liability

EN BEFORE ASSEMBLING YOUR GAZEBO

DE VOR DEM ZUSAMMENBAU IHRER PERGOLA

FR AVANT D'ASSEMBLER VOTRE PERGOLA

NL VOORDAT U UW PERGOLA MONTEERT

EN WARNING: Important safety instructions. Follow all instructions, since incorrect assembly can lead to severe injury.

Make sure you have all the tools required for assembling your gazebo:

In order to assemble your gazebo safely and correctly, please ensure you have access to the following tools and accessories, all of which are not provided.

DE WARNUNG: Wichtige Sicherheitshinweise. Befolgen Sie alle Anweisungen, da eine falsche Montage zu schweren Verletzungen führen kann.

Vergewissern Sie sich, dass Sie alle für die Montage Ihrer Pergola erforderlichen Werkzeuge besitzen:

Um Ihre Pergola sicher und korrekt montieren zu können, vergewissern Sie sich bitte, dass Sie Zugang zu den folgenden Werkzeugen und Zubehörteilen haben, die nicht alle mitgeliefert werden.

FR AVERTISSEMENT: Instructions de sécurité importantes. Suivez toutes les instructions, car un assemblage incorrect peut entraîner des blessures graves.

Assurez-vous d'avoir tous les outils nécessaires au montage de votre pergola:

Afin d'assembler votre pergola correctement et en toute sécurité, assurez-vous d'avoir accès aux outils et accessoires suivants, qui ne sont pas tous fournis.

NL WAARSCHUWING: Belangrijke veiligheidsinstructies. Volg alle instructies op, want een verkeerde montage kan ernstig letsel tot gevolg hebben.

Zorg ervoor dat u al het gereedschap heeft dat nodig is om uw pergola te monteren:

Om uw pergola veilig en correct te monteren, dient u ervoor te zorgen dat u de volgende gereedschappen en accessoires tot uw beschikking heeft. Deze worden niet allemaal meegeleverd.



EN BEFORE ASSEMBLING YOUR GAZEBO

DE VOR DEM ZUSAMMENBAU IHRER PERGOLA

FR AVANT D'ASSEMBLER VOTRE PERGOLA

NL VOORDAT U UW PERGOLA MONTEERT

EN

Check to ensure there are no missing parts:

Before you begin assembly, please check that you have all the parts required to assemble your gazebo. Please also carefully check that the quantity of parts matches with that of the model you have purchased.

If any parts are missing, please refer to the **Warranty & Complaints Procedure** to contact customer service before beginning the assembly.

Prepare the parts you will need for each step:

In the **Assembly** section of the manual, each step indicates the necessary parts and quantities required to complete the step. We recommend that you prepare the parts you will need for each assembly step. Doing this will save you time and effort during assembly. If possible, place the parts on cardboard or other soft surface to protect from scratching the painted surfaces.

DE

Überprüfen Sie, dass keine Teile fehlen:

Bevor Sie mit dem Aufbau beginnen, überprüfen Sie bitte, ob Sie alle Teile haben, die Sie für den Aufbau Ihrer Pergola benötigen. Bitte überprüfen Sie auch sorgfältig, ob die Anzahl der Teile mit der des von Ihnen gekauften Modells übereinstimmt.

Sollten Teile fehlen, wenden Sie sich bitte an den Kundendienst, bevor Sie mit dem Zusammenbau beginnen, siehe **Garantie- und Reklamationsverfahren**.

Legen Sie die Teile bereit, die Sie für jeden Schritt benötigen:

Im Abschnitt **„Montage“** des Handbuchs sind für jeden Schritt die erforderlichen Teile und Mengen angegeben, die für den jeweiligen Schritt benötigt werden. Wir empfehlen Ihnen, die Teile, die Sie für jeden Montageschritt benötigen, vorzubereiten. So sparen Sie beim Zusammenbau Zeit und Mühe. Legen Sie die Teile nach Möglichkeit auf Karton oder eine andere weiche Unterlage, um Kratzer auf den lackierten Oberflächen zu vermeiden.

FR

Vérifiez qu'il ne manque aucune pièce:

Avant de commencer le montage, vérifiez que vous disposez de toutes les pièces nécessaires à l'assemblage de votre pergola. Vérifiez également que la quantité de pièces correspond à celle du modèle que vous avez acheté.

S'il manque des pièces, veuillez vous référer à la **procédure de garantie et de réclamation** pour contacter le service clientèle avant de commencer l'assemblage.

Préparez les pièces dont vous aurez besoin pour chaque étape:

Dans la section **Assemblage** du manuel, chaque étape indique les pièces nécessaires et les quantités requises pour la réaliser. Nous vous recommandons de préparer les pièces dont vous aurez besoin pour chaque étape de l'assemblage. Vous gagnerez ainsi du temps et de l'énergie lors de l'assemblage. Si possible, placez les pièces sur un carton ou une autre surface souple pour éviter de rayer les surfaces peintes.

NL

Controleer of er geen onderdelen ontbreken:

Controleer voordat u met de montage begint of u alle benodigde onderdelen voor de montage van uw pergola heeft. Controleer ook zorgvuldig of het aantal onderdelen overeenkomt met het model dat u heeft gekocht.

Mocht er een onderdeel ontbreken, raadpleeg dan de **Garantie- en klachtenprocedure** om contact op te nemen met de klantenservice voordat u met de montage begint.

Bereid de onderdelen voor die u voor elke stap nodig heeft:

In het hoofdstuk **Montage** van de handleiding worden bij elke stap de benodigde onderdelen en aantallen aangegeven die nodig zijn om de stap te voltooien. Wij adviseren u om de onderdelen die u voor elke montageshap nodig heeft, alvast klaar te leggen. Hiermee bespaart u tijd en moeite tijdens de montage. Leg de onderdelen indien mogelijk op karton of een ander zacht oppervlak om krassen op de geverfde oppervlakken te voorkomen.

EN BEFORE ASSEMBLING YOUR GAZEBO

DE VOR DEM ZUSAMMENBAU IHRER PERGOLA

FR AVANT D'ASSEMBLER VOTRE PERGOLA

NL VOORDAT U UW PERGOLA MONTEERT

EN Select a suitable location:

DE Wählen Sie einen geeigneten Standort:

FR Sélectionnez un lieu approprié:

NL Selecteer een geschikte locatie:



- EN The ground should be solid and flat
- DE Der Boden sollte fest und flach sein
- FR Le sol doit être solide et plat
- NL De ondergrond moet stevig en vlak zijn



- EN Sufficient water drainage
- DE Ausreichender Wasserabfluss
- FR Drainage d'eau suffisant
- NL Voldoende waterafvoer

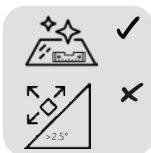

- EN The ground should be level
- DE Der Boden sollte eben sein
- FR Le sol doit être plat
- NL De ondergrond moet waterpas zijn

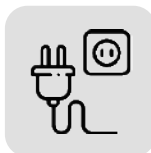

- EN Easy access to power
- DE Leichter Zugang zu Strom
- FR Accès facile à l'électricité
- NL Gemakkelijke toegang tot stroom



- EN No overhanging trees and powerlines
- DE Keine überhängenden Bäume und Stromleitungen
- FR Pas d'arbres ou de lignes électriques en surplomb
- NL Geen overhangende bomen en elektriciteitskabels

EN Warning: Most terraces or patios are designed with a slight slope to prevent (rain) water from forming pools or reaching the house or other structures. For the perfect gazebo assembly, a level surface without such a slope is required. Small pebbles could also prevent the gazebo from being safely secured on the ground.

If the gazebo is installed on an uneven surface, it may prevent accessory components from working correctly and may void the product warranty.

Prepare a foundation:

- To prepare it, you need to:
- check for underground pipes and cables (Call 811 before you dig if you live in the USA)
 - check with your local authorities regarding any building permits that may be required
 - contact a reliable contractor to install a concrete base if you don't have one

Do not assemble the gazebo on sandy, muddy or loose soil, as the stakes do not have the sufficient anchorage to be installed in these types of soil.

EN BEFORE ASSEMBLING YOUR GAZEBO

DE VOR DEM ZUSAMMENBAU IHRER PERGOLA

FR AVANT D'ASSEMBLER VOTRE PERGOLA

NL VOORDAT U UW PERGOLA MONTEERT

DE Warning: Die meisten Terrassen oder Innenhöfe sind mit einem leichten Gefälle angelegt, um zu verhindern, dass (Regen-)Wasser Pfützen bildet oder das Haus oder andere Strukturen erreicht. Für die perfekte Pergola-Montage ist eine ebene Fläche ohne ein solches Gefälle erforderlich. Kleine Kieselsteine könnten auch verhindern, dass die Pergola sicher auf dem Boden steht.

Wenn die Pergola auf einem unebenen Untergrund aufgestellt wird, können die Zubehörteile nicht richtig funktionieren und die Produktgarantie kann erlöschen.

Bereiten Sie ein Fundament vor:

- Um es vorzubereiten, müssen Sie:
- Achten Sie auf unterirdische Rohre und Kabel (rufen Sie 811 an, bevor Sie graben, wenn Sie in den USA leben)
 - Erkundigen Sie sich bei den örtlichen Behörden, ob eine Baugenehmigung erforderlich ist
 - Wenden Sie sich an einen zuverlässigen Bauunternehmer, um einen Betonsockel zu installieren, falls Sie keinen haben

Montieren Sie die Pergola nicht auf sandigem, schlammigem oder lockerem Boden, da die Pfähle nicht ausreichend verankert sind, um in solchen Böden installiert zu werden.

FR Avertissement: La plupart des terrasses ou des patios sont conçus avec une légère pente pour éviter que l'eau (de pluie) ne forme des mares ou n'atteigne la maison ou d'autres structures. Pour une installation parfaite de la pergola, il faut une surface en béton plane, sans pente. De petits cailloux peuvent également empêcher la pergola d'être fixée au sol en toute sécurité.

Si la pergola est installée sur une surface irrégulière, cela peut empêcher les accessoires de fonctionner correctement et annuler la garantie du produit.

Préparer une fondation:

- Pour la préparer, vous devez :
- vérifier s'il y a des tuyaux et des câbles souterrains (appelez le 811 avant de creuser si vous vivez aux États-Unis)
 - vérifier auprès des autorités locales si un permis de construire est nécessaire
 - contacter un entrepreneur fiable pour installer une base en béton si vous n'en avez pas

Ne montez pas la pergola sur un sol sablonneux, boueux ou meuble, car les piquets n'ont pas l'ancrage suffisant pour être installés dans ce type de sol.

NL Waarschuwing: De meeste terrassen en patio's zijn ontworpen met een lichte helling om te voorkomen dat (regen)water plassen vormt of het huis of andere gebouwen bereikt. Voor een perfecte montage van de pergola is een vlakke ondergrond zonder helling vereist. Kleine kiezels kunnen er ook voor zorgen dat de pergola niet stevig op de grond staat.

Als de pergola op een oneffen oppervlak wordt geïnstalleerd, is het mogelijk dat de bijbehorende onderdelen niet goed functioneren en dat de productgarantie vervalt.

Bereid een fundering voor:

- Om het te bereiden, moet u het volgende doen:
- controleer op ondergrondse leidingen en kabels (Bel 811 voordat u gaat graven als u in de VS woont)
 - informeer bij uw plaatselijke instanties naar eventuele bouwvergunningen die vereist zijn
 - neem contact op met een betrouwbare aannemer om een betonnen fundering te installeren als u die niet hebt

Monteer de pergola niet op zanderige, modderige of losse grond. De palen hebben dan onvoldoende verankering om de pergola in deze grondsoorten te bevestigen.

EN IMPORTANT SAFETY ADVICE

DE WICHTIGE SICHERHEITSHINWEISE

FR CONSEILS DE SÉCURITÉ IMPORTANTS

NL BELANGRIJK VEILIGHEIDSADVIES

EN For the safety of all persons assembling and using the gazebo, it is important to follow the safety guidelines below.

DE Für die Sicherheit aller Personen, die die Pergola montieren und benutzen, ist es wichtig, die nachstehenden Sicherheitshinweise zu beachten.

FR Pour la sécurité de toutes les personnes qui montent et utilisent la pergola, il est important de respecter les consignes de sécurité suivantes.

NL Voor de veiligheid van alle personen die de pergola monteren en gebruiken, is het belangrijk om de onderstaande veiligheidsrichtlijnen op te volgen.



EN The gazebo must be positioned and fixed on flat level surface.

DE Die Pergola muss auf einer flachen, ebenen Fläche aufgestellt und befestigt werden.

FR La pergola doit être positionnée et fixée sur une surface plane et horizontale.

NL De pergola moet op een vlakke, waterpas ondergrond worden geplaatst en bevestigd.



EN Always wear appropriate work shoes, gloves and eye protection when working.

DE Tragen Sie bei der Arbeit immer geeignete Arbeitsschuhe, Handschuhe und einen Augenschutz.

FR Portez toujours des chaussures de travail, des gants et des lunettes de protection appropriés.

NL Draag tijdens het werk altijd geschikte werkschoenen, handschoenen en een oogbescherming.



EN Work well away from power lines, particularly when handling metal parts.

DE Arbeiten Sie in ausreichendem Abstand zu Stromleitungen, insbesondere bei der Handhabung von Metallteilen.

FR Travaillez à bonne distance des lignes électriques, en particulier lorsque vous manipulez des pièces métalliques.

NL Werk uit de buurt van hoogspanningskabels, vooral bij het hanteren van metalen onderdelen.



EN If using power tools or a ladder, always follow the manufacturer's safety instructions.

DE Befolgen Sie bei der Verwendung von Elektrowerkzeugen oder Leitern stets die Sicherheitshinweise des Herstellers.

FR Si vous utilisez des outils électriques ou une échelle, suivez toujours les instructions de sécurité du fabricant.

NL Bij gebruik van elektrisch gereedschap of een ladder, volg dan altijd de veiligheidsinstructies van de fabrikant.

EN IMPORTANT SAFETY ADVICE

DE WICHTIGE SICHERHEITSHINWEISE

FR CONSEILS DE SÉCURITÉ IMPORTANTS

NL BELANGRIJK VEILIGHEIDSADVIES



EN Make sure the gazebo complies with local building regulatory codes.

DE Vergewissern Sie sich, dass die Pergola den örtlichen Bauvorschriften entspricht.

FR Assurez-vous que la pergola est conforme aux réglementations locales en matière de construction.

NL Zorg ervoor dat de pergola voldoet aan de plaatselijke bouwvoorschriften.

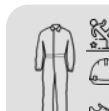

EN Working at heights can be dangerous. Always wear protective clothing to prevent injury in the event of a fall.

DE Arbeiten in großer Höhe können gefährlich sein. Tragen Sie immer Schutzkleidung, um Verletzungen im Falle eines Sturzes zu vermeiden.

FR Le travail en hauteur peut être dangereux. Portez toujours des vêtements de protection pour éviter les blessures en cas de chute.

NL Werken op hoogte kan gevaarlijk zijn. Draag altijd beschermende kleding om letsel te voorkomen bij een val.

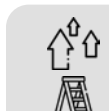

EN Only use ladders and scaffolding with a sufficiently high load bearing capacity.

DE Verwenden Sie nur Leitern und Gerüste mit einer ausreichend hohen Tragfähigkeit.

FR N'utilisez que des échelles et des échafaudages dont la capacité de charge est suffisamment élevée.

NL Gebruik uitsluitend ladders en steigers met een voldoende draagvermogen.



EN Keep clothing and body parts away from the gazebo to prevent them from getting caught in the moving parts.

DE Halten Sie Kleidung und Körperteile von der Pergola fern, damit sie sich nicht in den beweglichen Teilen verfangen können.

FR Éloignez les vêtements et les parties du corps de la pergola afin d'éviter qu'ils ne se prennent dans les parties mobiles.

NL Houd kleding en lichaamsdelen uit de buurt van de pergola om te voorkomen dat ze vast komen te zitten in de bewegende delen.

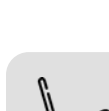

EN Foliage or other foreign objects on the louvers and in the guide rails should be removed regularly, to prevent damage to the gazebo.

DE Laub oder andere Fremdkörper auf dem Dach und in den Führungsschienen sollten regelmäßig entfernt werden, um Schäden an der Pergola zu vermeiden.

FR Les feuillages et autres corps étrangers se trouvant sur le toit et dans les rails de guidage doivent être enlevés régulièrement afin d'éviter d'endommager la pergola.

NL Bladeren en andere vreemde voorwerpen op het dak en in de geleiderails moeten regelmatig worden verwijderd om schade aan de pergola te voorkomen.



EN Only use replacement parts that are approved by the manufacturer.

DE Verwenden Sie nur Ersatzteile, die vom Hersteller zugelassen sind.

FR N'utilisez que des pièces de rechange approuvées par le fabricant.

NL Gebruik uitsluitend vervangende onderdelen die door de fabrikant zijn goedgekeurd.

EN IMPORTANT SAFETY ADVICE**DE WICHTIGE SICHERHEITSHINWEISE****FR CONSEILS DE SÉCURITÉ IMPORTANTS****NL BELANGRIJK VEILIGHEIDSADVIES**

- EN** Put the louvers into the vertical position during snowfall or wind to avoid damage.
- DE** Bringen Sie die Lamellen bei Schneefall oder Wind in die senkrechte Position, um Schäden zu vermeiden.
- FR** Placez les persiennes en position verticale en cas de chute de neige ou de vent afin d'éviter tout dommage.
- NL** Zet de lamellen bij sneeuwval of wind verticaal om schade te voorkomen.

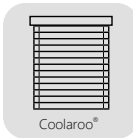

- EN** Installation of non-Coolaroo branded accessories will void the product warranty and can damage the operating mechanism.
- DE** Die Installation von Zubehörteilen, die nicht von Coolaroo stammen, führt zum Erlöschen der Produktgarantie und kann den Betriebsmechanismus beschädigen.
- FR** L'installation d'accessoires d'une autre marque que Coolaroo annule la garantie du produit et peut endommager le mécanisme de fonctionnement.
- NL** Bij installatie van accessoires die niet van het merk Coolaroo zijn, vervalt de productgarantie en kan het bedieningsmechanisme beschadigd raken.



- EN** After prolonged use we recommend you check all the fittings are tightened securely.
- DE** Nach längerem Gebrauch empfehlen wir Ihnen, zu überprüfen, ob alle Beschläge fest angezogen sind.
- FR** Après une utilisation prolongée, nous vous recommandons de vérifier que tous les raccords sont bien serrés.
- NL** Na langdurig gebruik adviseren wij u te controleren of alle fittingen goed vastzitten.



- EN** Please recycle packaging where possible.
- DE** Bitte recyceln Sie die Verpackung, wenn möglich.
- FR** Dans la mesure du possible, recyclez les emballages.
- NL** Recycle de verpakking indien mogelijk.

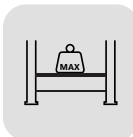

- EN** Do not exceed the weight limit when using the bar shelf. (bar shelf: 132lbs/60kg)
- DE** Überschreiten Sie nicht die Gewichtsgrenze, wenn Sie das Regal benutzen. (Stangenablage: 132lbs/60kg).
- FR** Ne pas dépasser la limite de poids lors de l'utilisation de l'étagère à barres. (étagère à barre : 132 lbs/60 kg).
- NL** Overschrijd de gewichtslimiet niet bij gebruik van de plank. (barplank: 132 lbs/60 kg).

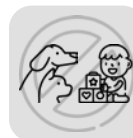

- EN** Dispose of all plastic bags safely. Keep them out of the reach of children.
- DE** Entsorgen Sie alle Plastiktüten sicher. Bewahren Sie sie außerhalb der Reichweite von Kindern auf.
- FR** Jetez tous les sacs en plastique en toute sécurité. Ne les laissez pas à la portée des enfants.
- NL** Gooi alle plastic zakken op een veilige manier weg. Buiten bereik van kinderen houden.

EN IMPORTANT SAFETY ADVICE**DE WICHTIGE SICHERHEITSHINWEISE****FR CONSEILS DE SÉCURITÉ IMPORTANTS****NL BELANGRIJK VEILIGHEIDSADVIES**

- EN** Keep children and pets away from the assembly area until the work is completed.
- DE** Halten Sie Kinder und Haustiere vom Montagebereich fern, bis die Arbeiten abgeschlossen sind.
- FR** Tenez les enfants et les animaux domestiques à l'écart de la zone de montage jusqu'à ce que les travaux soient terminés.
- NL** Houd kinderen en huisdieren uit de buurt van de montageplek totdat de werkzaamheden zijn afgerond.



- EN** Do not attempt to assemble the product if you are tired, or after consuming alcohol.
- DE** Versuchen Sie nicht, das Produkt zu montieren, wenn Sie müde sind oder Alkohol konsumiert haben.
- FR** N'essayez pas d'assembler le produit si vous êtes fatigué ou après avoir consommé de l'alcool.
- NL** Probeer het product niet in elkaar te zetten als u moe bent of nadat u alcohol heeft gedronken.



- EN** Do not attempt to assemble the gazebo in windy or wet conditions.
- DE** Versuchen Sie nicht, die Pergola bei Wind oder Nässe zu montieren.
- FR** N'essayez pas d'assembler la pergola lorsqu'il y a du vent ou de l'humidité.
- NL** Probeer de pergola niet te monteren bij winderige of natte omstandigheden.



- EN** Do not climb on the louvers.
- DE** Klettern Sie nicht auf das Dach.
- FR** Ne montez pas sur le toit.
- NL** Klim niet op het dak.

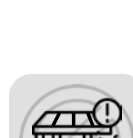

- EN** Prior to each operation, visually check the gazebo for damage. If damage is visible, stop using it immediately and contact authorized personnel to repair the damage.
- DE** Überprüfen Sie die Pergola vor jedem Einsatz visuell auf Schäden. Wenn Schäden sichtbar sind, stellen Sie die Benutzung sofort ein und wenden Sie sich an autorisiertes Personal, um den Schaden zu beheben.
- FR** Avant chaque opération, vérifiez visuellement que la pergola n'est pas endommagée. Si des dommages sont visibles, cessez immédiatement de l'utiliser et contactez le personnel autorisé pour réparer les dommages.
- NL** Controleer de pergola vóór elke handeling visueel op schade. Als er zichtbare schade is, stop dan onmiddellijk met het gebruik en neem contact op met bevoegd personeel om de schade te laten repareren.



- EN** Do not touch moving parts during operation.
- DE** Berühren Sie während des Betriebs keine beweglichen Teile.
- FR** Ne touchez pas les pièces mobiles pendant le fonctionnement.
- NL** Raak geen bewegende delen aan tijdens het gebruik.

EN IMPORTANT SAFETY ADVICE

FR CONSEILS DE SÉCURITÉ IMPORTANTS

DE WICHTIGE SICHERHEITSHINWEISE

NL BELANGRIJK VEILIGHEIDSADVIES

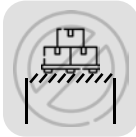

- EN Do not place anything on the louvers.
- DE Legen Sie keine Gegenstände auf das Dach.
- FR Ne placez rien sur le toit.
- NL Plaats niets op het dak.



- EN Hanging objects on the gazebo may cause serious damage and is not permitted.
- DE Das Aufhängen von Gegenständen an der Pergola kann schwere Schäden verursachen und ist nicht erlaubt.
- FR L'accrochage d'objets sur la pergola peut causer de graves dommages et n'est pas autorisé.
- NL Het ophangen van voorwerpen aan de pergola kan ernstige schade veroorzaken en is daarom niet toegestaan.



- EN Changes to the design or configuration of equipment may not be made without consulting the manufacturer or authorized representative.
- DE Ohne Rücksprache mit dem Hersteller oder einem autorisierten Vertreter dürfen keine Änderungen an der Konstruktion oder Konfiguration der Geräte vorgenommen werden.
- FR Il est interdit de modifier la conception ou la configuration de l'équipement sans consulter le fabricant ou son représentant autorisé.
- NL Wijzigingen in het ontwerp of de configuratie van apparatuur mogen niet worden aangebracht zonder overleg met de fabrikant of een bevoegde vertegenwoordiger.



- EN Do not start the roof mechanism in case of frost or ice build-up, as it may damage the drive of the louvers.
- DE Starten Sie den Dachmechanismus nicht bei Frost oder Eisbildung, da dies den Antrieb der Lamellen beschädigen könnte.
- FR Ne mettez pas en marche le mécanisme de la toiture en cas de gel ou d'accumulation de glace, car cela pourrait endommager l'entraînement des persiennes.
- NL Start het dakmechanisme niet bij vorst of ijsvorming, omdat dit de aandrijving van de lamellen kan beschadigen.

EN LIST OF PARTS

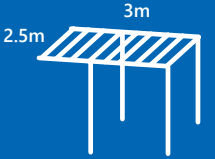

DE LISTE DER TEILE

FR LISTE DES PIÈCES

NL ONDERDELENLIJST

EN Please carefully check that the quantity of parts matches with that of the model you have purchased.

PLEASE NOTE that the anchor bolts provided may not be suitable for your chosen installation location. Please check before proceeding.

DO NOT USE AN IMPACT CORDLESS SCREWDRIVER TO ASSEMBLE THE GAZEBO. USE A STANDARD CORDLESS SCREWDRIVER ON THE BASE SETTING. ALL HOLES HAVE BEEN PREDRILLED OR FITTED FOR ASSEMBLY.

DE Bitte überprüfen Sie sorgfältig, ob die Anzahl der Teile mit der des von Ihnen erworbenen Modells übereinstimmt.

BITTE BEACHTEN SIE, dass die mitgelieferten Ankerbolzen möglicherweise nicht für den von Ihnen gewählten Einbaort geeignet sind. Bitte überprüfen Sie dies, bevor Sie fortfahren.

VERWENDEN SIE FÜR DIE MONTAGE DER PERGOLA KEINEN AKKUSCHRAUBER. VERWENDEN SIE EINEN STANDARD-AKKUSCHRAUBER IN DER GRUNDEINSTELLUNG. ALLE LÖCHER SIND FÜR DIE MONTAGE VORGEBOHRT ODER EINGEPASST.

FR Veuillez vérifier soigneusement que la quantité de pièces correspond à celle du modèle que vous avez acheté.

VEUILLEZ NOTER que les boulons d'ancrage fournis peuvent ne pas convenir au lieu d'installation que vous avez choisi. Veuillez vérifier avant de procéder.

N'UTILISEZ PAS DE TOURNEVIS SANS FIL À PERCUSSION POUR ASSEMBLER LA PERGOLA. UTILISEZ UN TOURNEVIS SANS FIL STANDARD POUR LE RÉGLAGE DE LA BASE. TOUS LES TROUS ONT ÉTÉ PRÉ-PERCÉS OU AJUSTÉS POUR L'ASSEMBLAGE.

NL Controleer zorgvuldig of het aantal onderdelen overeenkomt met het model dat u heeft gekocht.

HOUD ER REKENING MEE dat de meegeleverde ankerbouten mogelijk niet geschikt zijn voor de door u gekozen installatielocatie. Controleer het volgende voordat u verdergaat.

GEBRUIK GEEN SLAGMOTORSCHROEVENDRAAIER OM DE PERGOLA TE MONTEREN. GEBRUIK EEN STANDAARD ACCUBOORMACHINE OP DE BASISSTAND ALLE GATEN ZIJN VOORGEBOORD OF GEMONTEERD VOOR MONTAGE.

EN LIST OF PARTS

FR LISTE DES PIÈCES

EN *Extra spare parts included





FR *Pièces de rechange supplémentaires incluses

DE LISTE DER TEILE

NL ONDERDELENLIJST

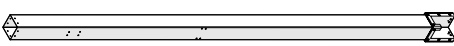
DE *Einschließlich zusätzlicher Ersatzteile

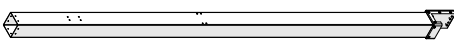
NL *Extra reserveonderdelen meegeleverd





A		1	EN Corner Pillar 1
			DE Eckpfeiler 1
			FR Pilier d'angle 1
			NL Hoekstaander 1
A1		1	EN Corner Pillar 2
			DE Eckpfeiler 2
			FR Pilier d'angle 2
			NL Hoekstaander 2
A2		1	EN Corner Pillar 3
			DE Eckpfeiler 3
			FR Pilier d'angle 3
			NL Hoekstaander 3
A3		1	EN Corner Pillar 4
			DE Eckpfeiler 4
			FR Pilier d'angle 4
			NL Hoekstaander 4
A4		2	EN Beam connector
			DE Balkenverbinder
			FR Connecteur de poutre
			NL Verbindingsstuk voor balk

EN LIST OF PARTS

FR LISTE DES PIÈCES

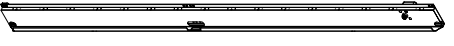
DE LISTE DER TEILE

NL ONDERDELENLIJST

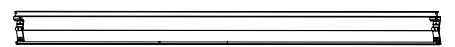



B		1	EN Side beam with gearbox
			DE Seitenträger mit Getriebe
			FR Poutre latérale avec la boîte de vitesses
			NL Zijbalk met versnellingsbak
B1		1	EN Side beam without gearbox
			DE Seitenträger ohne Getriebe
			FR Poutre latérale sans boîte de vitesses
			NL Zijbalk zonder versnellingsbak
C		1	EN End beam 1
			DE Endbalken 1
			FR Poutre d'extrémité 1
			NL Eindbalk 1
C1		1	EN End beam 2
			DE Endbalken 2
			FR Poutre d'extrémité 2
			NL Eindbalk 2
D		1	EN Driving Louver
			DE Antriebslamelle
			FR Volet d'entraînement
			NL Bewegende lamel

EN LIST OF PARTS

FR LISTE DES PIÈCES

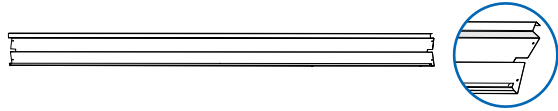

DE LISTE DER TEILE

NL ONDERDELENLIJST

D1		15	EN Louver
			DE Lamelle
			FR Volet
			NL Lamel
E		2	EN Footrest
			DE Fußstütze
			FR Repose-pieds
			NL Voetsteun
F		2	EN Bar shelf
			DE Barablage
			FR Étagère de bar
			NL Plank
G		2	EN Connecting strip
			DE Verbindungsleiste
			FR Bande de raccordement
			NL Verbindingsstrip
H		1	EN Crank
			DE Kurbel
			FR Manivelle
			NL Zwenkhendel



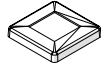

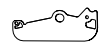
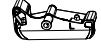
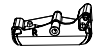
EN LIST OF PARTS

FR LISTE DES PIÈCES

I		4	EN Foot plate cover
			DE Abdeckung der Fußplatte
			FR Couvercle de l'embase
			NL Afdekking voor voetplaat
J		4	EN Foot plate
			DE Fußplatte
			FR Plaque de pied
			NL Voetplaat
K		1	EN Louver end cap
			DE Lamellenendkappe
			FR Embout de la persienne
			NL Eindkap voor lamel
K1		15+1*	EN Louver end cap L
			DE Lamellenendkappe L
			FR Embout de la persienne L
			NL Eindkap voor linker lamel
K2		15+1*	EN Louver end cap R
			DE Lamellenendkappe R
			FR Embout de la persienne R
			NL Eindkap voor rechter lamel



DE LISTE DER TEILE

NL ONDERDELENLIJST

L		1	EN Louver end cap with control arm
			DE Lamellenendkappe mit Steuerarm
			FR Embout de persienne avec bras de commande
			NL Eindkap voor lamel met bedieningsarm
M1		32+8*	EN Shaft support cover
			DE Abdeckung der Wellenabstützung
			FR Couvercle de support d'arbre
			NL Afdekking voor assteun
M2		32+8*	EN Shaft seat
			DE Schachtsitz
			FR Siège de raccordement d'arbre
			NL Ashouder
N		1	EN Corner pillar cover
			DE Eckpfilerabdeckung
			FR Couvercle du pilier d'angle
			NL Afdekking voor hoekstaander
N2		1	EN Corner pillar cover (logo)
			DE Eckpfilerabdeckung (logo)
			FR Couvercle du pilier d'angle (logo)
			NL Afdekking voor hoekstaander (logo)



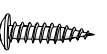

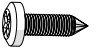
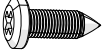
EN LIST OF PARTS

FR LISTE DES PIÈCES

O		96+4*	EN Screw ST5.5x23mm
			DE Schraube ST5.5x23mm
			FR Vis ST5,5x23mm
			NL Zelftappende schroef 5,5x23 mm
P		2	EN Connecting fixed axis
			DE Verbindung der festen Achse
			FR Axe fixe de raccordement
			NL Verbindende vaste as
Q		34+5*	EN Screw ST4.2x25mm
			DE Schraube ST4.2x25mm
			FR Vis ST4,2x25mm
			NL Zelftappende schroef 4,2x25 mm
R		60+4*	EN Screw ST4.8x16mm
			DE Schraube ST4.8x16mm
			FR Vis ST4,8x16mm
			NL Zelftappende schroef 4,8x16 mm
R1		38+2*	EN Screw ST5.5x16mm
			DE Schraube ST5.5x16mm
			FR Vis ST5,5x16mm
			NL Zelftappende schroef 5,5x16 mm





DE LISTE DER TEILE

NL ONDERDELENLIJST

R2		32+2*	EN Washer ø12x6x2mm
			DE Unterlegscheibe ø12x6x2mm
			FR Rondelle ø12x6x2mm
			NL Sluitring ø12x6x2 mm
S		6+2*	EN Cotter pin
			DE Splint
			FR Goupille fendue
			NL Splitpen
T		2	EN Louver shaft
			DE Lamellenwelle
			FR Axe de volet
			NL As van lamel
U		16+2*	EN Screw M8x16mm
			DE Schraube M8x16mm
			FR Vis M8x16mm
			NL Schraube M8x16mm
U1		16+2*	EN Screw M8x18mm
			DE Schraube M8x18mm
			FR Vis M8x18mm
			NL Schroef M8 x18 mm



EN LIST OF PARTS

FR LISTE DES PIÈCES

V		1	EN Crank coupler
			DE Kurbelkupplung
			FR Coupleur de manivelle
			NL Zwenkhendel
W		16	EN Anchor bolt M8x80mm
			DE Ankerbolzen M8x80mm
			FR Boulon d'ancrage M8x80 mm
			NL Ankerbout M8 x 80 mm
X		1	EN Hex key M5
			DE Sechskantschlüssel M5
			FR Clé hexagonale M5
			NL Inbussleutel M5
Y		2	EN Hex key S6
			DE Sechskantschlüssel S6
			FR Clé hexagonale S6
			NL Inbussleutel S6
Y1		2	EN Hex key M6
			DE Sechskantschlüssel M6
			FR Clé hexagonale M6
			NL Inbussleutel M6

DE LISTE DER TEILE

NL ONDERDELENLIJST

Z		1	EN 12mm SDS Plus Drill Bit
			DE 12mm SDS Plus Bohrer
			FR Foret SDS Plus de 12 mm
			NL 12 mm SDS Plus boortje
Z10		0+10*	EN Spare plastic pin
			DE Ersatz-Kunststoffstift
			FR Goupille en plastique de rechange
			NL Reserve kunststof pen

EN ASSEMBLY

DE ZUSAMMENBAU

FR ASSEMBLAGE

NL MONTAGE

Assembly Video



1. Set up the corner pillars

1A

Slide the foot plate cover **I** with its wide opening facing outwards on the straight end of the pillars

- I** x 4
- A** x 1
- A1** x 1
- A2** x 1
- A3** x 1

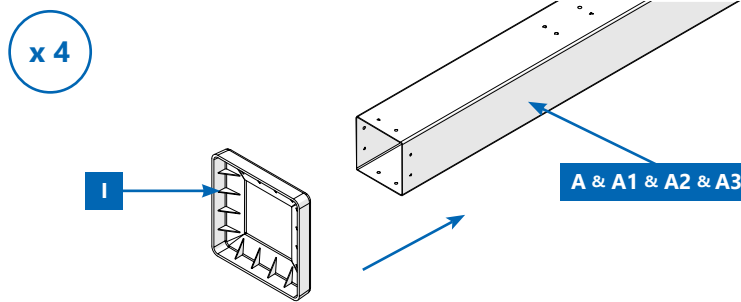

1B

Insert the foot plate **J** into the straight end of the pillars **A** & **A1** & **A2** & **A3** and secure it with 8 screws **O**.

- O** x 32
- J** x 4

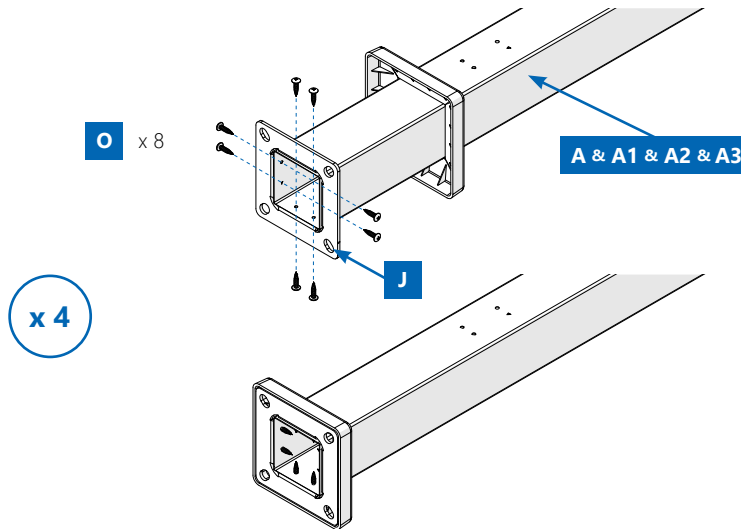

2. Connect the side beam to the pillars

2A

Lay two pillars **A**, **A2**, beam connector **A4** and the side beam with gearbox **B** on the ground, as shown in the picture.

- A4** x 1
- A** x 1
- A2** x 1
- B** x 1

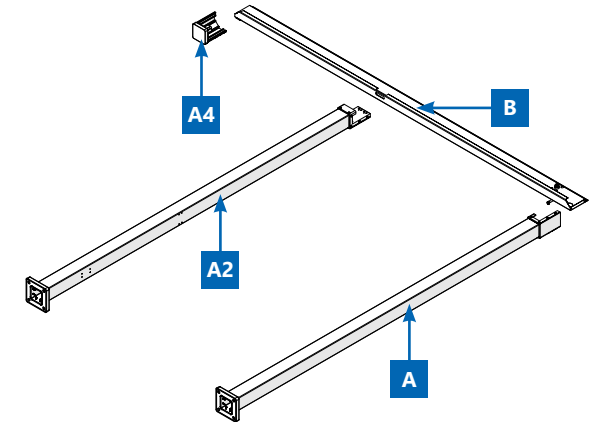

2B

Using hex key M6 **Y1**, slightly loosen the built-in screws on the upper side of side beam with gearbox **B**. Using hex key S6 **Y**, slightly loosen the built-in screws on the bottom side.

- Y1** x 1
- Y** x 1

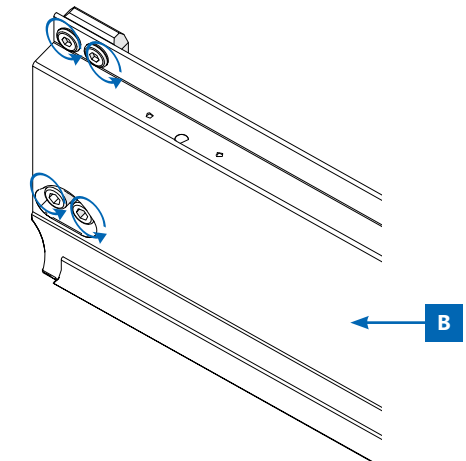

2C

Slide the side beam with gearbox **B** into the grooves of the pillars, in such a way that the slot nuts of the side beam interlock with those of the pillars and connector.

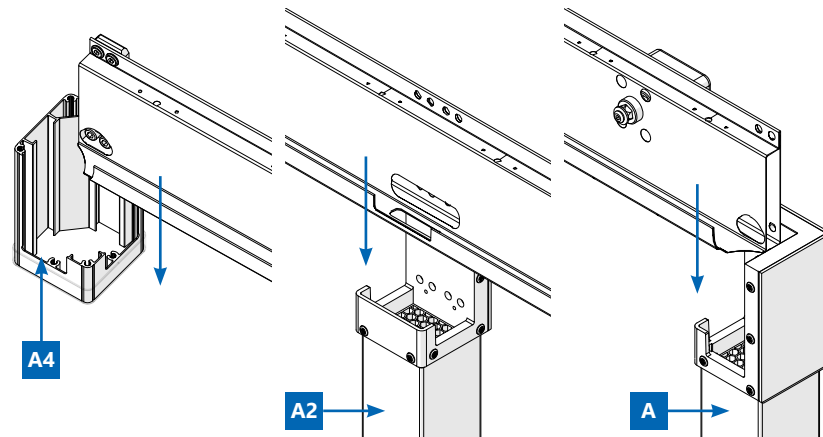

2D

Insert screw **U** on the upper side of the side beam with gearbox **B**, and screw **U1** on the bottom side.

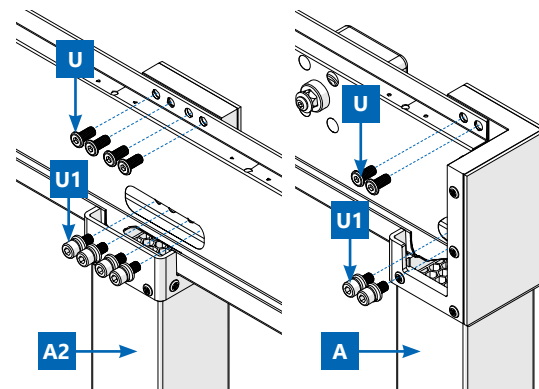

2E

Tighten the upper side screws using hex key M6 **Y1**, and the bottom side screws using hex key S6 **Y**.

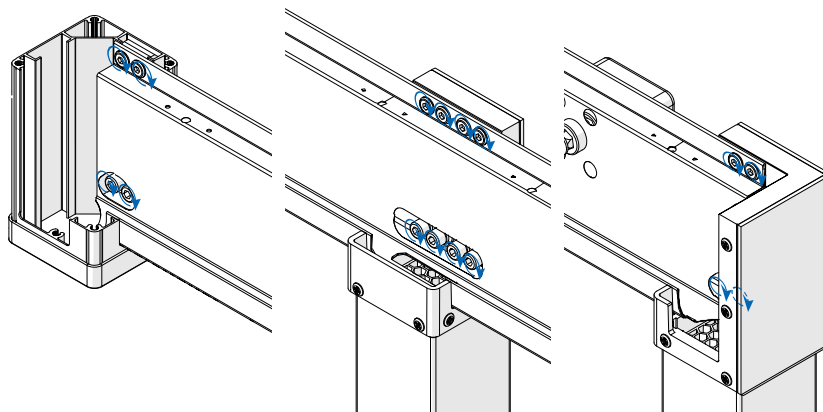

2F

Repeat steps 2A - 2E to connect the side beam without gearbox **B1** to the remaining two pillars **A1** & **A3** and beam connector **A4**.

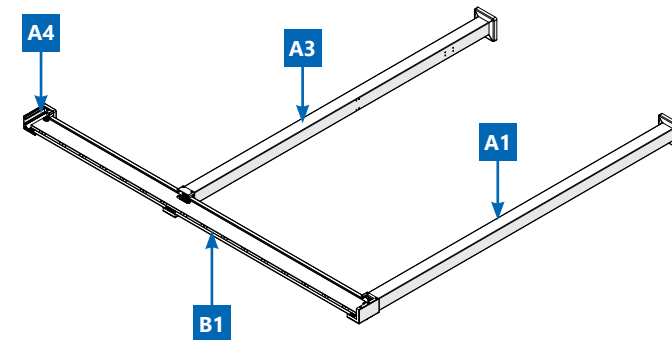
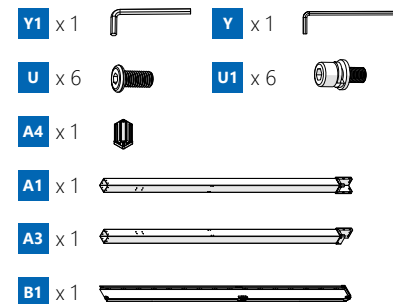

3. Assemble end beams

This phase requires 4 persons and at least 2 stepladders. Make sure that the stepladders are standing securely to avoid falling. Only use ladders suitable for this kind of assembly work.



3A

Stand the two structures built in **steps 2** in an upright position, and place them at one end beam length away from one another. Make sure that one person is supporting each corner leg to prevent the structures from falling.

Notice:

When determining the installation direction of the product, please consider the opening direction of the louvers as well as the desired sunshade effect.

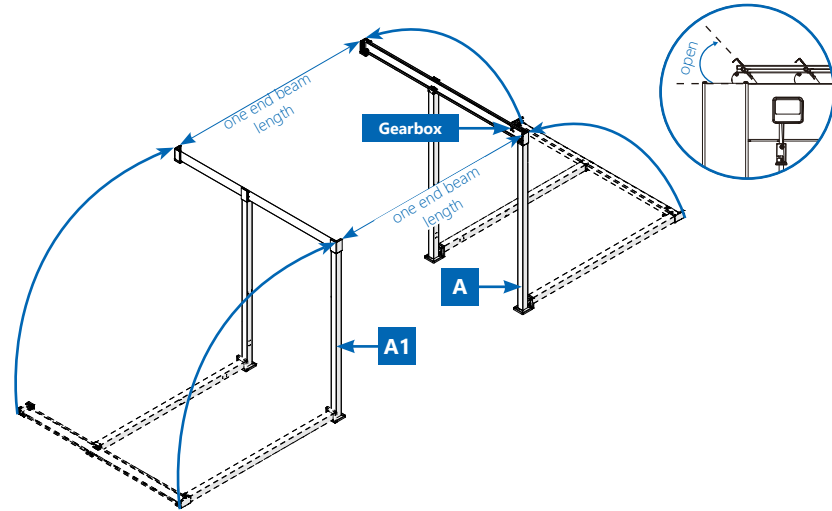

3B

Slide the end beams **C** from above into the slots of the corner pillars **A** & **A1**.

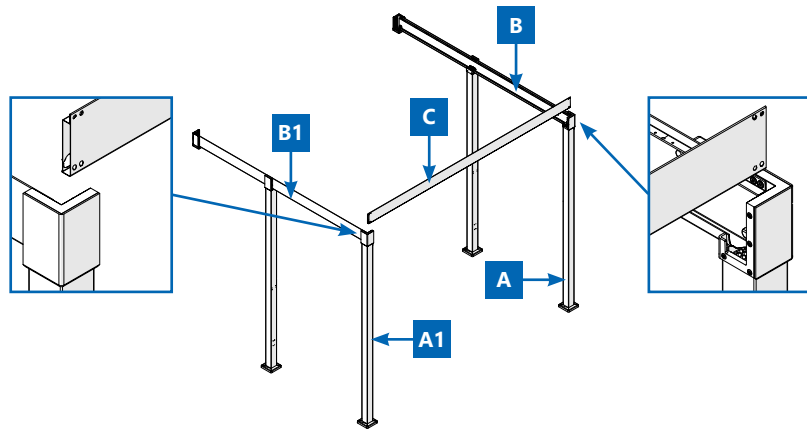

3C

Secure the end beam **C** with 2 screws **U** on the upper side by using hex key M6 **Y1** and 2 screws **U1** on the bottom side by using hex key S6 **Y**.

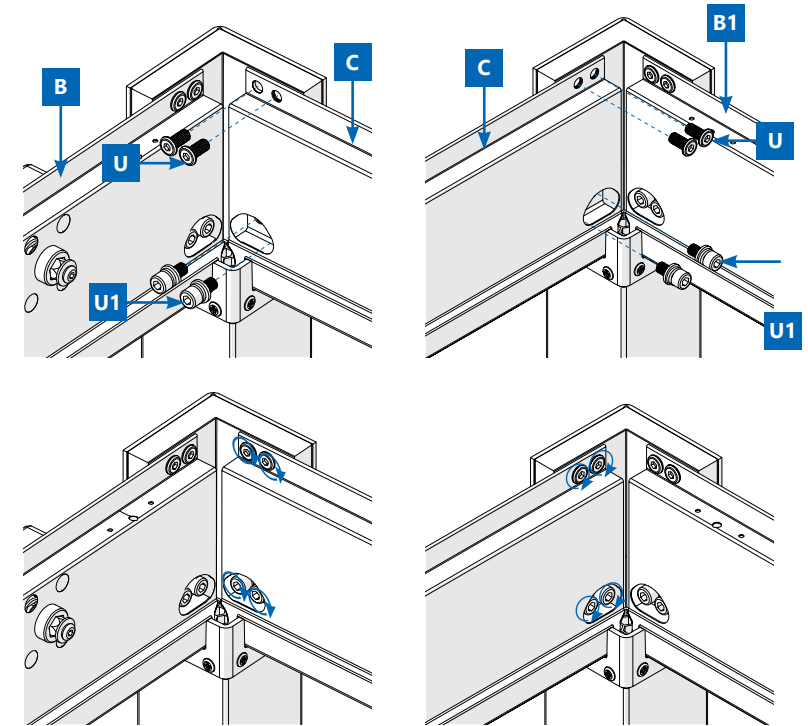
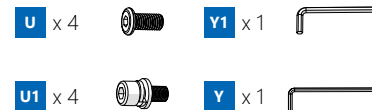

3D

Using hex key M6 **Y1**, slightly loosen the built-in screws on the upper side of end beam **C1**. Using hex key S6 **Y**, slightly loosen the built-in screws on the bottom side.

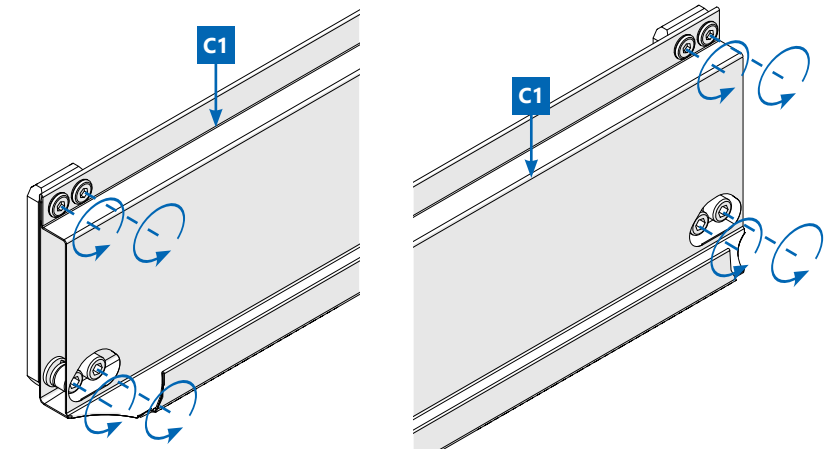

3E

Slide the slot nuts of the end beams **C1** from above into the slots of the beam connectors **A4**.

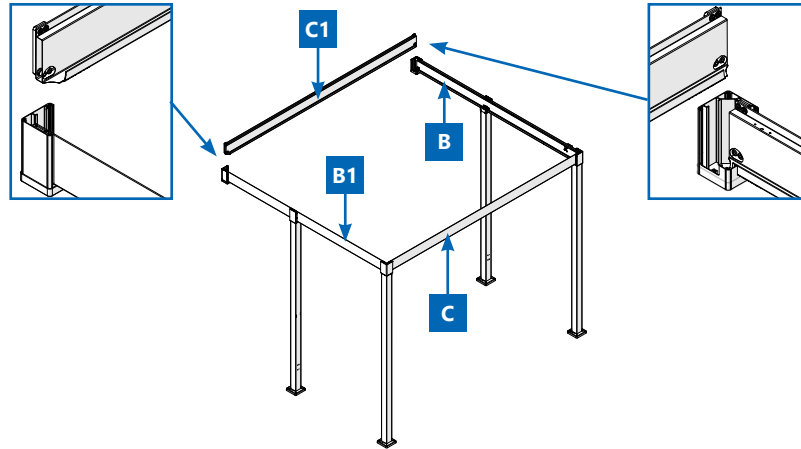

3F

Tighten the upper side screws using hex key **Y1**, and the bottom side screws using hex key **S6** **Y**.

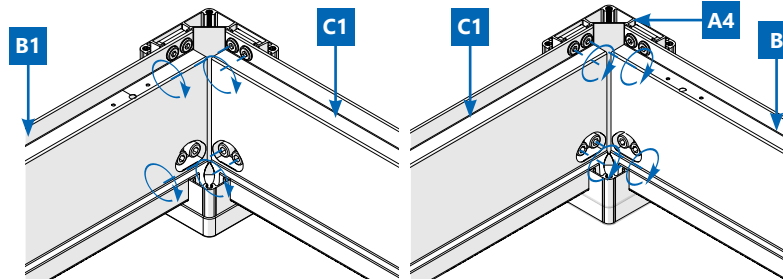

3G

Fix a pillar cover **N/N2** to the top of a beam connector **A4** with 3 screws each **R1**.

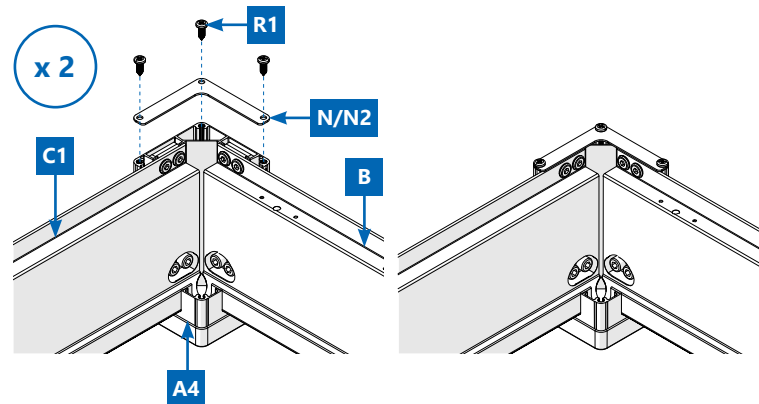

4. Check the alignment of the frame and the distance between the corner pillars

You are now almost done assembling the main frame of the gazebo. Please double check to ensure all beams and pillars have been assembled and fitted correctly. You may have to unscrew certain bolts during this step.

You will also need a tape measure and a leveler to complete this step.

4A

Choose one of the pillars and work from this pillar. Choose this pillar carefully as it will define the final installation location of the gazebo.

Use a leveler to measure against both of the inner sides to ensure that the corner pillar is straight and level.

Make sure this corner pillar does not move position during the remaining assembly steps.

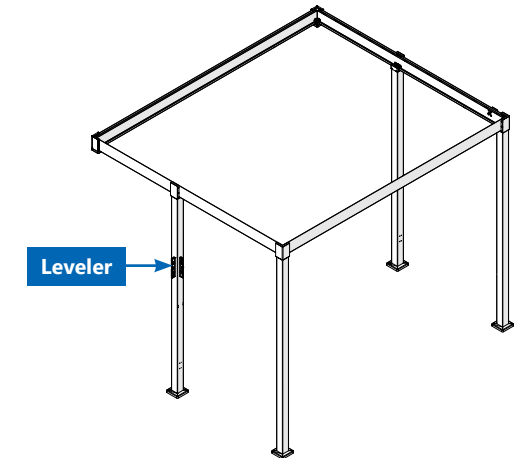

4B

Measure the distances between the adjacent corner pillars. Adjust accordingly and ensure the distances match those shown in the opposite figure.

a = 282.5 cm / 111.2 inches
b = 130.8 cm / 51.5 inches

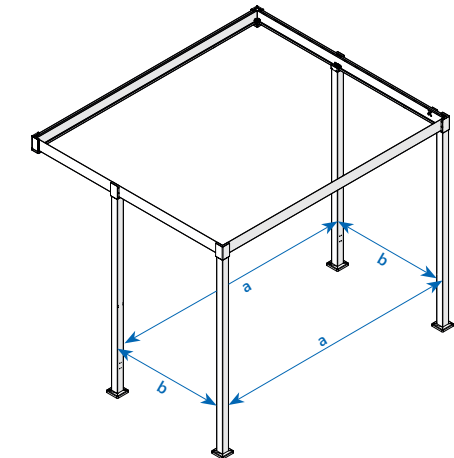

4C



Measure the diagonal distance between the opposite corner pillars. Adjust the other corner pillars accordingly until both diagonal distances are equal. You may have to repeat the above steps after completing the remaining steps.

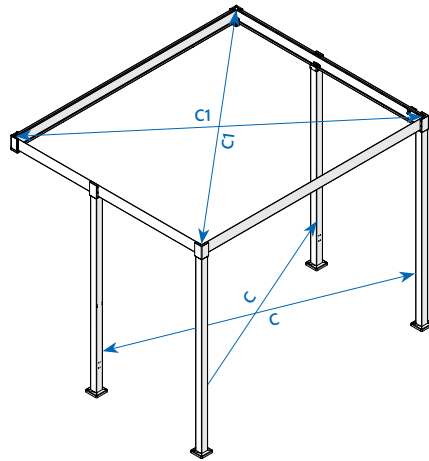

c = 311.5 cm / 122.6 inches
c1 = 390.7 cm / 153.8 inches

4D



Check that all corner pillars are straight and level using a leveler. If the corner pillars or beams are still not level, this means that your main building surface isn't sufficiently level, and that you will need to raise the corner pillars that are positioned lower than the others. (Contact qualified professional installers if needed.)

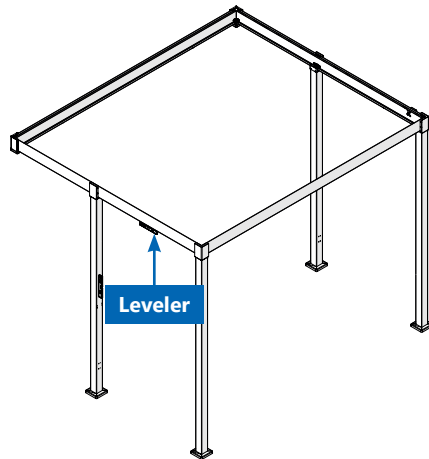

Warning:

If you do not adjust the main structure at this point, you may encounter problems when fitting the roof deck and/or accessories to the frame.

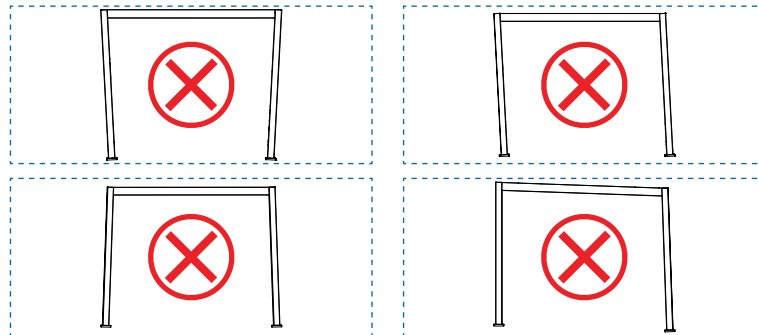

5. Assemble crank

5A

Locate the gearbox on the side beam with gearbox B.

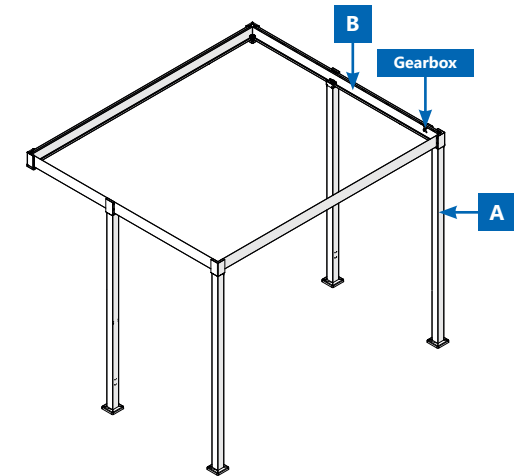

5B



Unscrew and remove the small screw from the crank connector.

Insert the crank coupler v into the crank connector and re-insert and tighten the small screw.

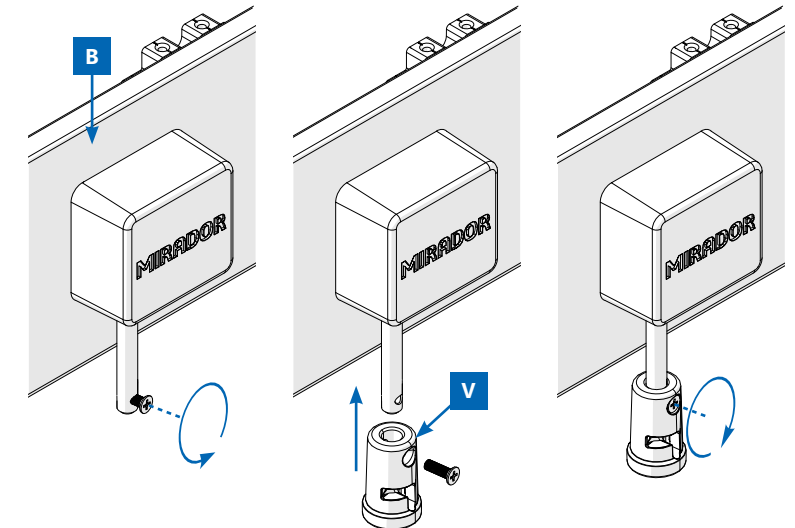

v x1



5C

Insert the end of the crank **H** into the crank coupler **V**, and turn until the crank locks firmly in place.

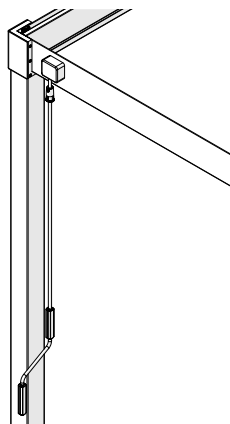
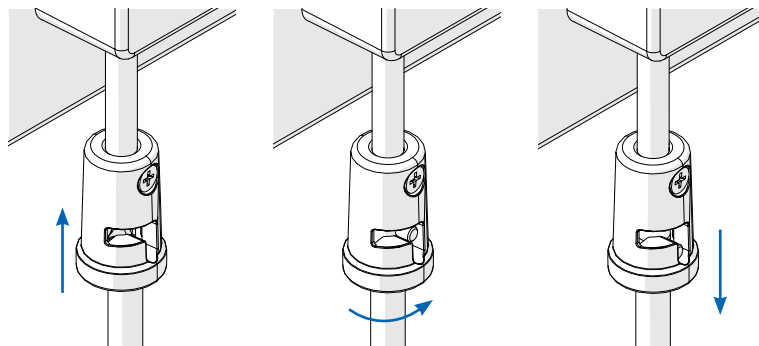
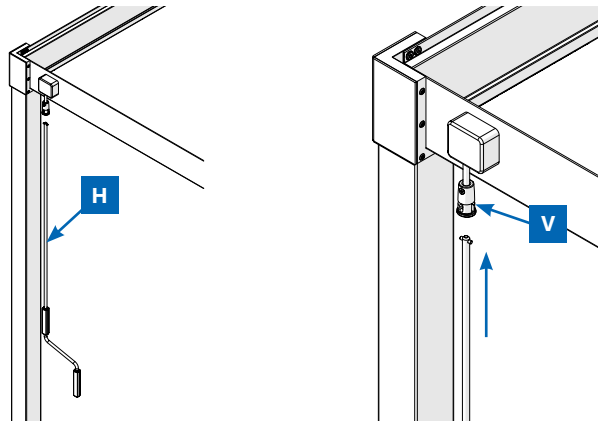

6. Assemble louvers & connecting strips

Prepare the driving louver

6A

Attach the louver end cap with control arm **L** to right end of the driving louver **D**. Use 2 screws **Q** to fix them firmly.

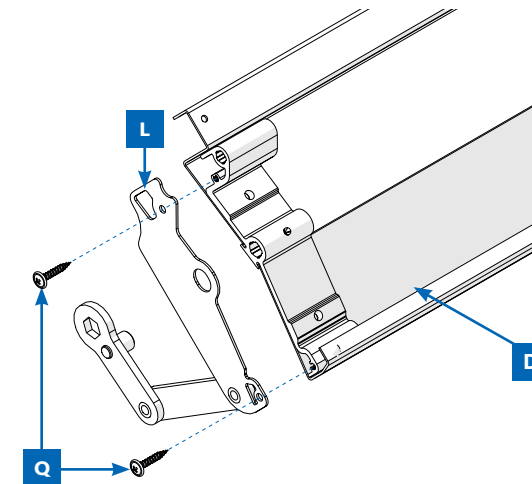
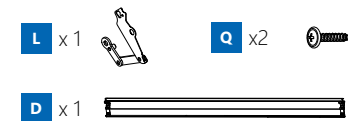

6B

Attach a louver end cap **K** to the other end of the driving louver and use 2 screws **Q** to fix them firmly.

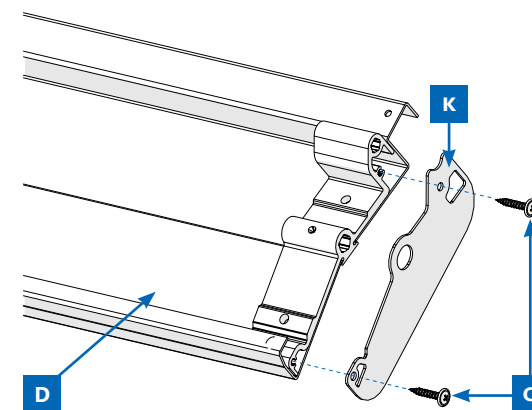

6C

Insert connecting fixed axis **P** and louver shaft **T** into the louver end cap with driving arm **L** and secure them with 2 cotter pin **S**.

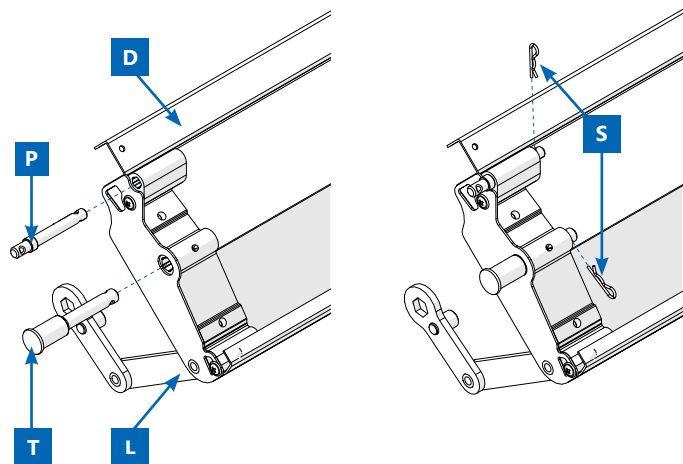
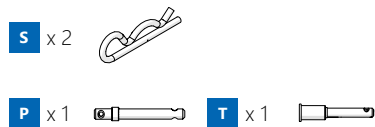

6D

Insert connecting fixed axis **P** and louver shaft **T** into the louver end cap **K** on the other side of the driving louver and secure them with 2 cotter pin **S**.

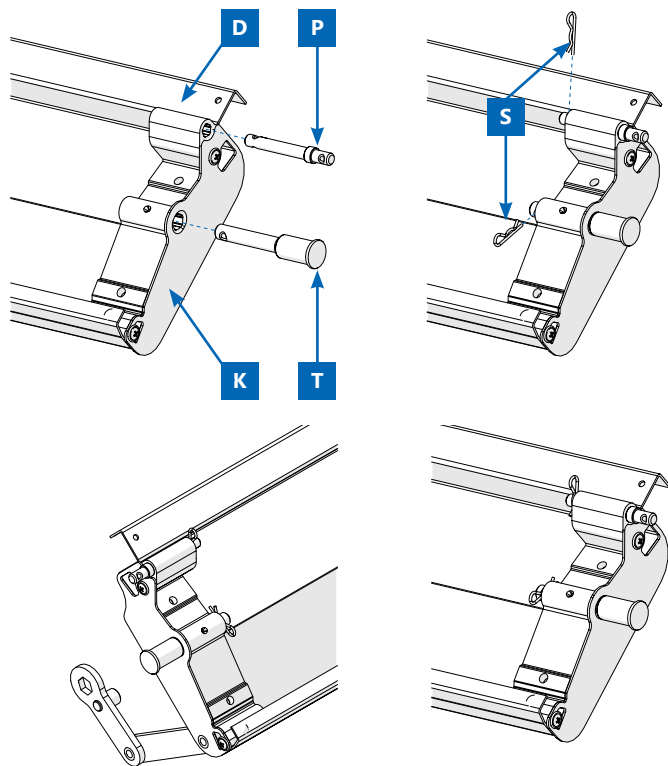
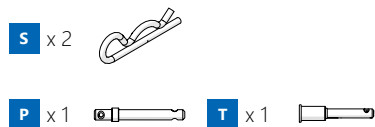

Prepare regular louvers

6E



Attach the louver end cap **K2** / **K1** to the right/left end of the louver **D1**. Use 2 screws **R** on each side, and fix them firmly.

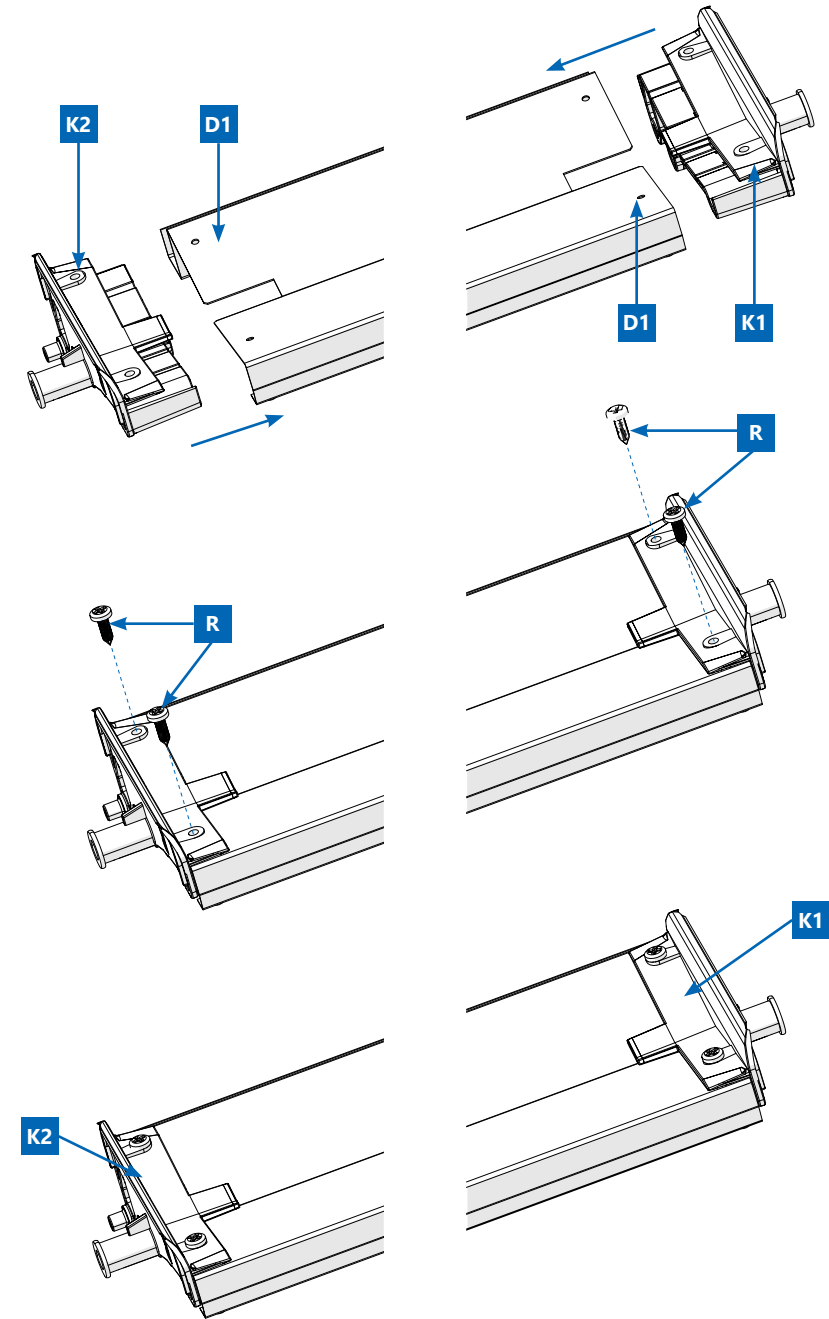
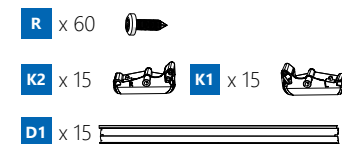

6F

Place the shaft seat **M2** at the **2nd position from the right** on both sides of the beams (**B** & **B1**), Loosen the screw and washer already attached to the beam **B**. Then fix the connecting rod **L** of the driving louver **D** to the side beam with gearbox **B**, by firmly tightening the same screw and washer, using the hexagon socket key **X**.

Place the driving louver **D** on the corresponding louver shaft support **M2** on both side beams (**B** & **B1**).

Notice:

Align the two hexagonal holes by adjusting the angle of the connecting rod **L** or rotating the crank **H**.

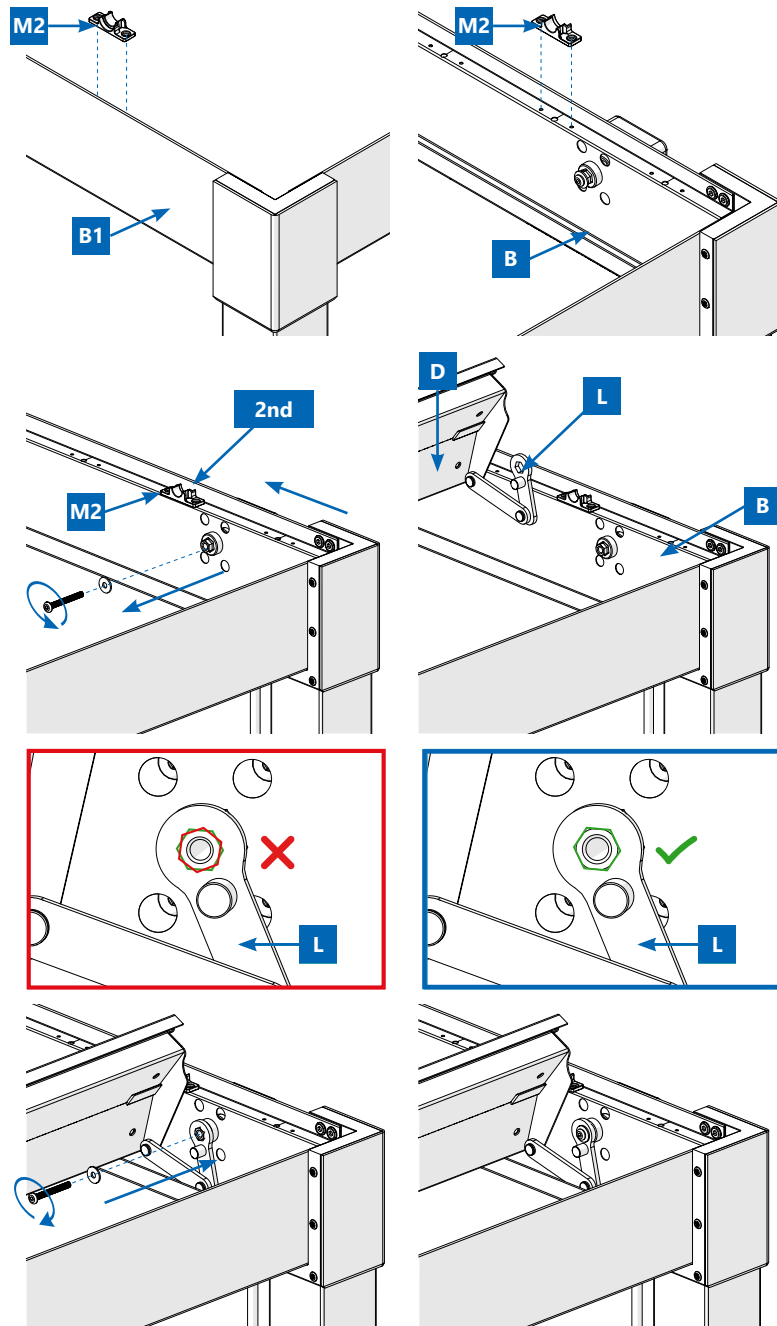

6G



Secure the driving louver **D** in the shaft support brackets by fixing a shaft support cover **M1** onto the shaft seat **M2** on both ends. Use two screws **O** each and secure them.

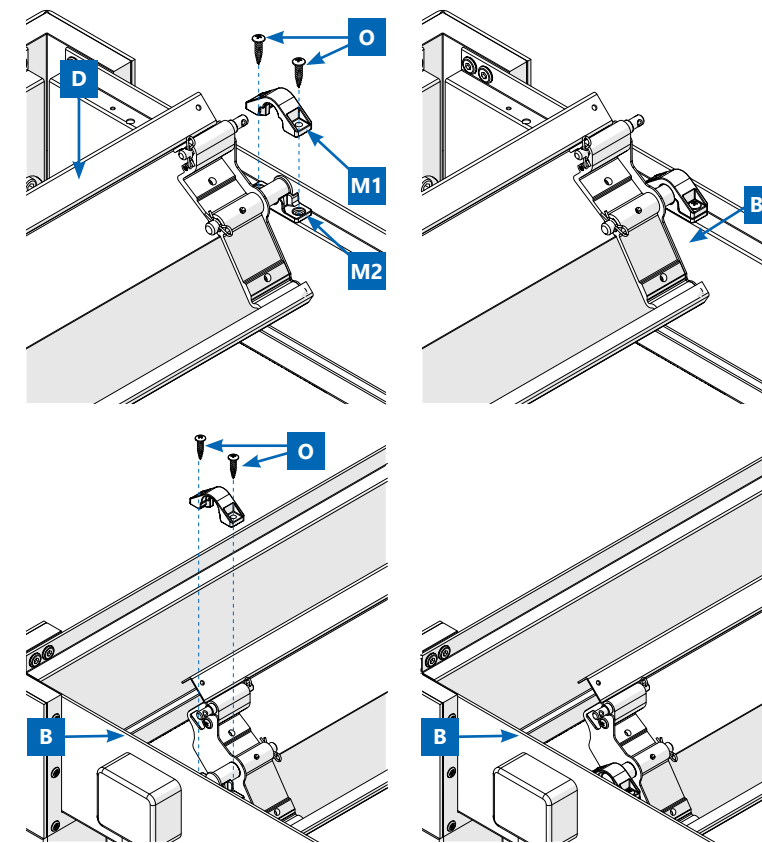

6H



Place the shaft seat **M2** on both sides of the beams (**B** & **B1**), and place the remaining louvers **D1** into the remaining shaft seats **M2**.

Secure the louvers **D1** in the shaft support brackets by fixing a shaft support cover **M1** onto the shaft seats **M2** on both ends. Use two screws **O** each and secure them.

Repeat this step for all louvers with each louver overlapping the next.

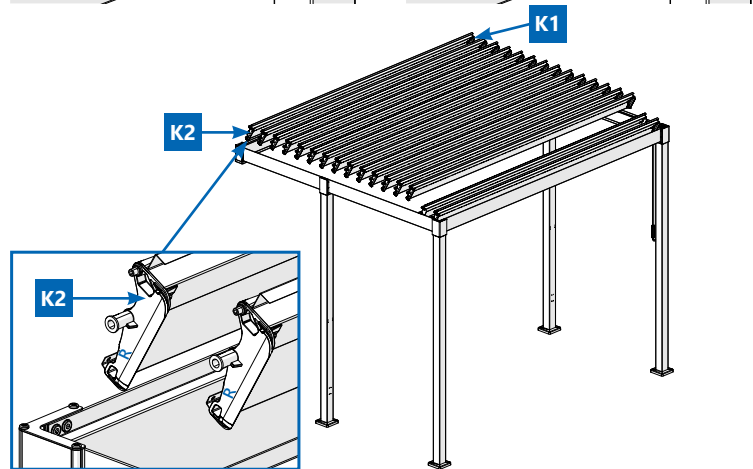
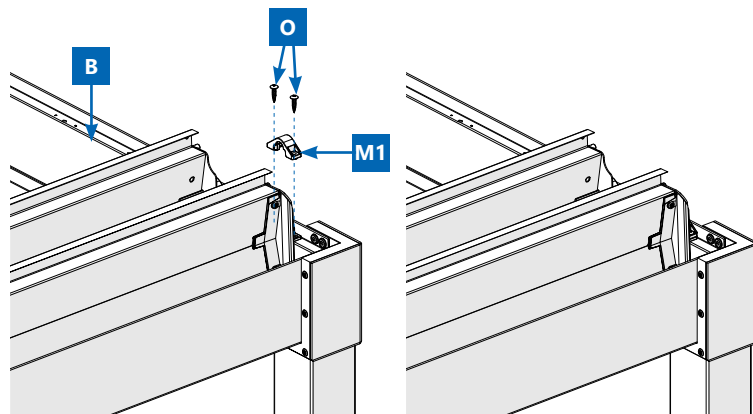
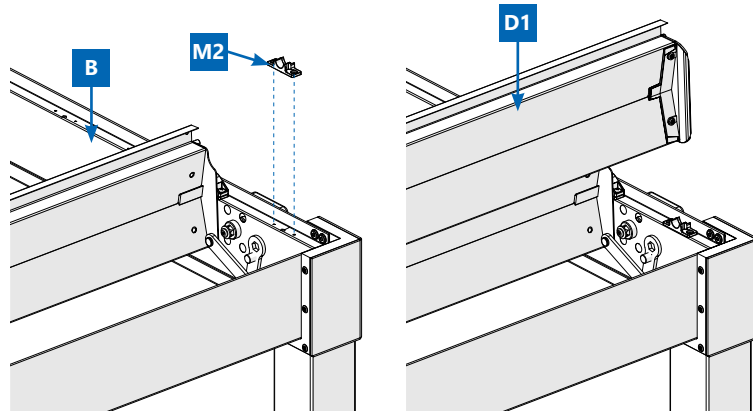

- O** x 60
- M1** x 30
- M2** x 30

6I



Take the connecting strip **G**. Attach it to each louver, fitting each of the holes onto the corresponding shaft of the louvers. To fix driving louver **D**, insert and secure a cotter pin **S** through the small shaft hole on the driving louver. Use 1 screw **Q** to fix each louver **D1** with **G** firmly.

Repeat this step for the other side.

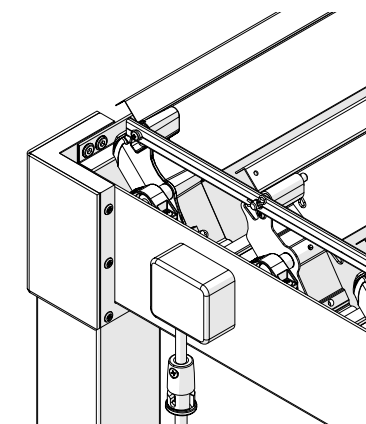
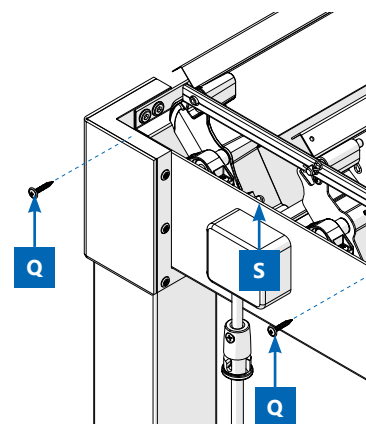
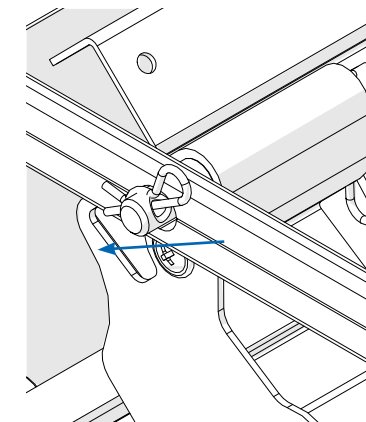
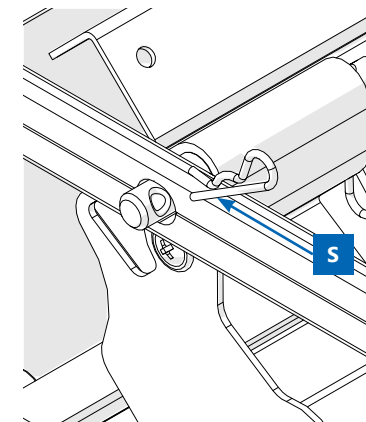
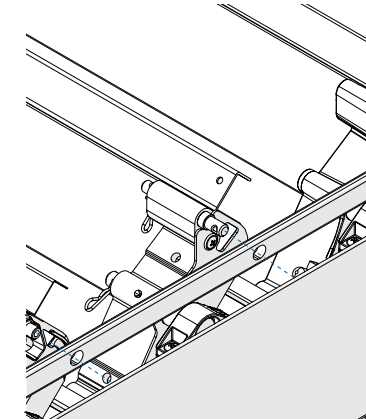
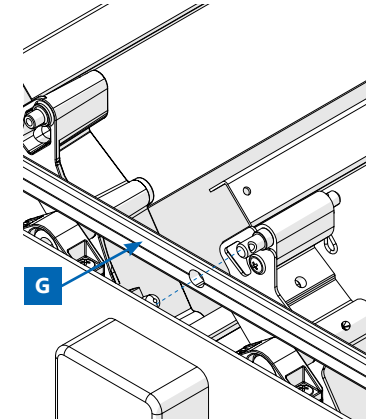

- S** x 2
- Q** x 30
- G** x 2

7. Assemble bar table & secure the gazebo to the ground



Align the mounting holes on the pillars and bar table top **F** and connect them with screws **R1** and washers **R2**.

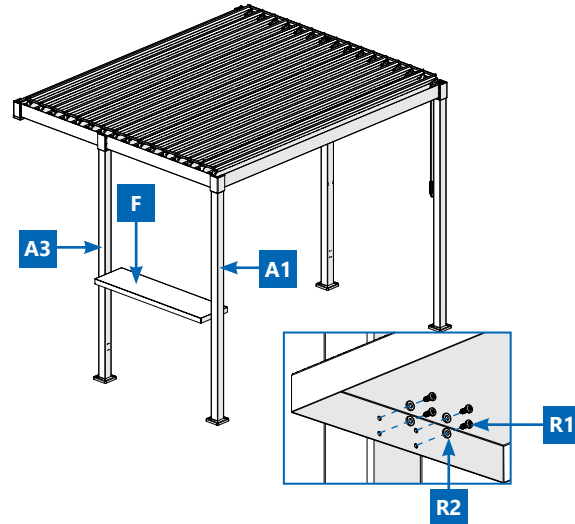

- F** x1
- R1** x8
- R2** x8



Assemble the bar table top **F** on the other side by repeating step **7A**.

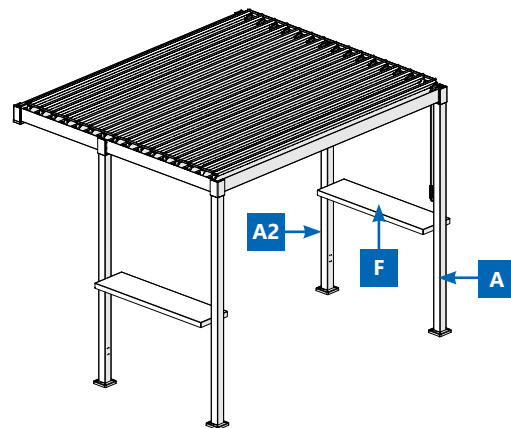

- F** x1
- R1** x8
- R2** x8

The gazebo must be firmly and permanently secured to the ground. If the ground is not level or suitable, please refer to the section "Before assembling your gazebo".



To fix the pillars with the four foot plates **J**, drill through each hole with a hammer drill.

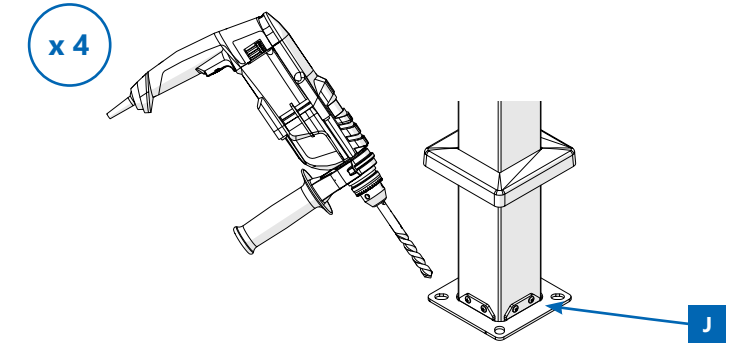

- Z** x1



Remove all the debris and dirt. Then firmly insert an anchor bolt **W** into each hole, using a hammer.

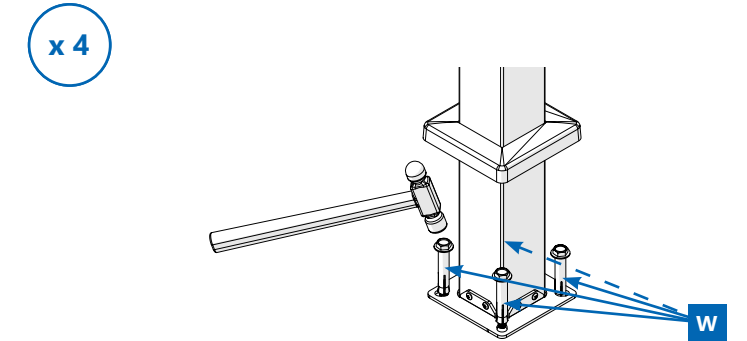

- W** x16



Align the mounting holes on the pillars and bar table pedal **E** and connect them with screws **R1** and washers **R2**.

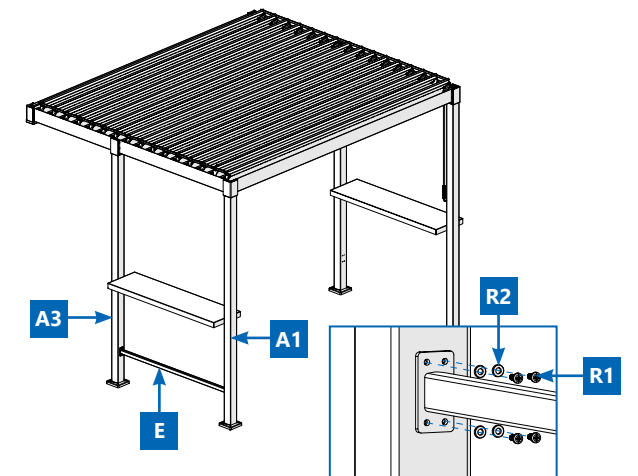

- E** x1
- R1** x8
- R2** x8



7F

Assemble the bar table pedal **E** on the other side by repeating step **7E**.

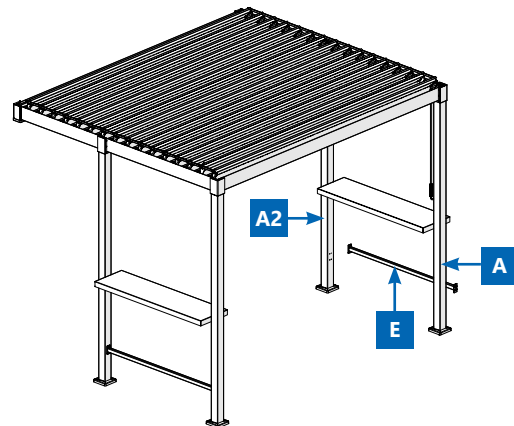

E x 1

R1 x 8 **R2** x 8



7G

Tighten the hexagonal ends of each bolt with a spanner/wrench.

x 4

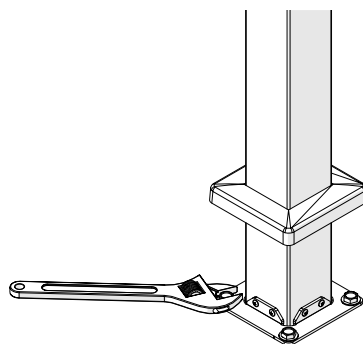

8. End of assembly

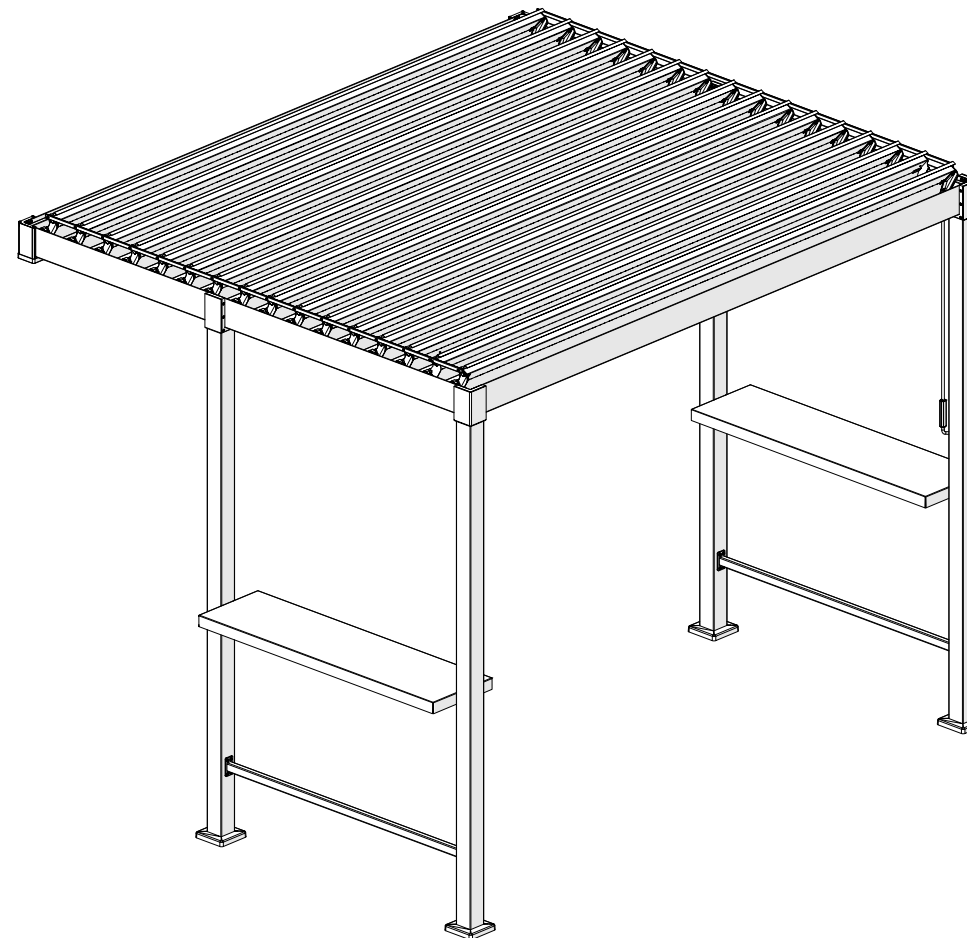

EN ASSEMBLY

DE ZUSAMMENBAU

FR ASSEMBLAGE

NL MONTAGE

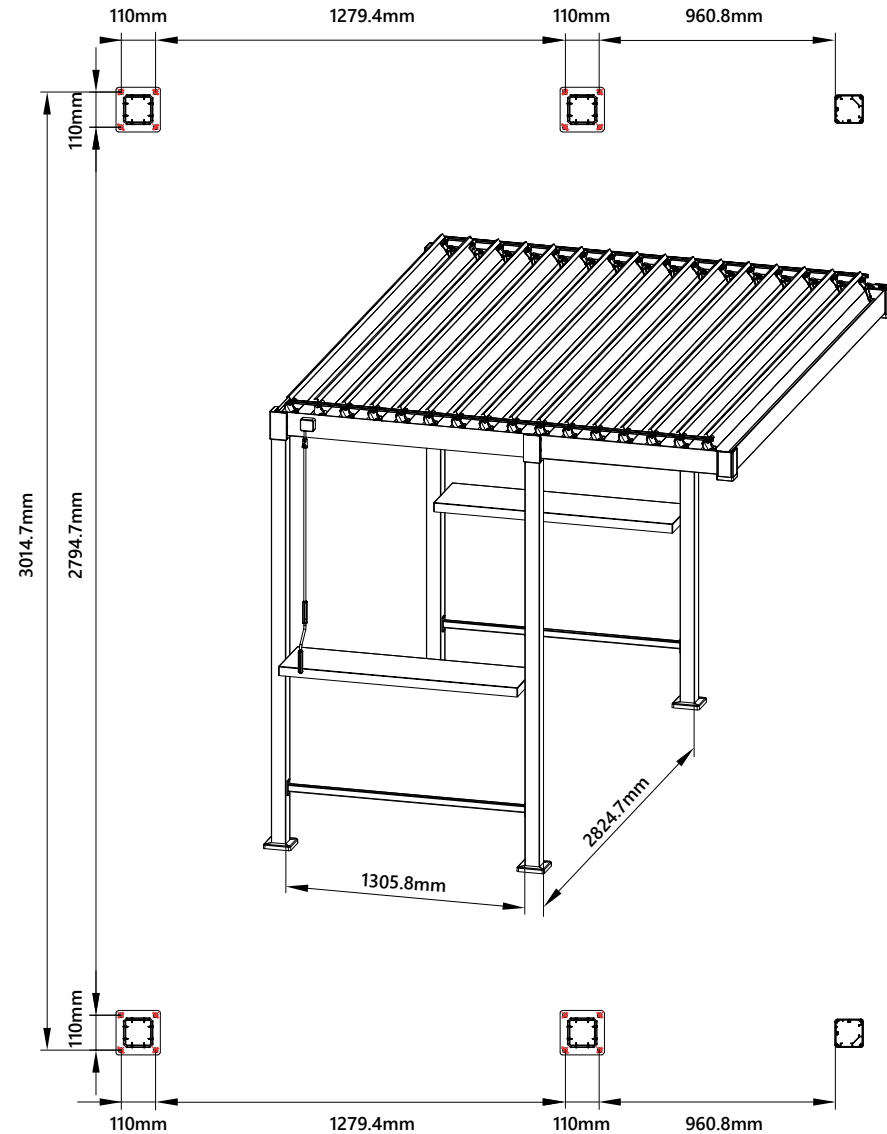

EN OPERATING YOUR GAZEBO

DE BETRIEB IHRER PERGOLA

FR FONCTIONNEMENT DE VOTRE PERGOLA

NL GEBRUIK VAN UW PERGOLA

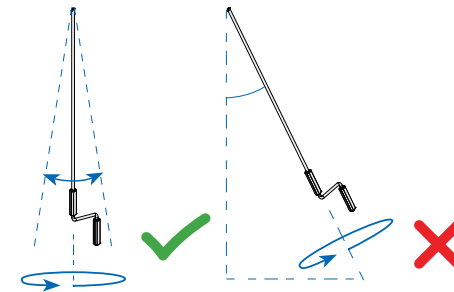

EN When opening/closing the louvers, please ensure the crank remains in a vertical position next to the pillar. Do not move the crank too far away from the pillar.

DE Achten Sie beim Öffnen/Schließen der Lamellen darauf, dass die Kurbel in einer senkrechten Position neben dem Pfeiler bleibt. Bewegen Sie die Kurbel nicht zu weit von der Säule weg.

FR Lorsque vous ouvrez/fermez les persiennes, veillez à ce que la manivelle reste en position verticale à côté du pilier. N'éloignez pas trop la manivelle du pilier.

NL Zorg ervoor dat de zwenkhandel verticaal naast de paal blijft staan als u de lamellen opent of sluit. Plaats de zwenkhandel niet te ver van de paal.

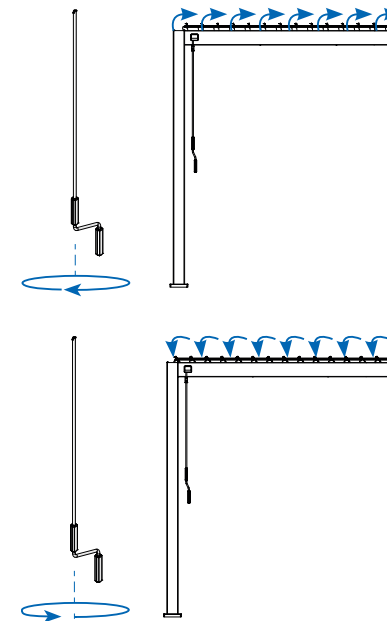

EN To open the louvers, turn the crank handle clockwise.

DE Zum Öffnen der Jalousie die Kurbel im Uhrzeigersinn drehen.

FR Pour ouvrir les persiennes, tournez la manivelle dans le sens des aiguilles d'une montre.

NL Om de lamellen te openen, draait u de zwenkhandel met de klok mee.

EN To close the louvers, turn the crank handle counter clockwise.

DE Um die Lamellen zu schließen, drehen Sie die Kurbel gegen den Uhrzeigersinn.

FR Pour fermer les persiennes, tournez la manivelle dans le sens inverse des aiguilles d'une montre.

NL Om de lamellen te sluiten, draait u de zwenkhandel tegen de klok in.

EN PROBLEM SOLVING

DE PROBLEMLÖSUNG

FR RÉOLUTION DE PROBLÈMES

NL PROBLEEMOPLOSSING

EN Issue	Explanation or action to take
Abnormal noise occurs during the rotation of the louvers.	Check if any of the louvers are deformed. If this is the case, replace them. If the louvers are not deformed but they are colliding with one another, replace the beam.
The flatness of the louver is damaged due to weather conditions.	Replace the affected louvers.
The drain is blocked by leaves or debris.	Clean the ducts and guttering of the gazebo regularly.
Water pocket resistance.	Class 1 (17 l/m ² per hour).
Mechanical endurance.	Class 1 (6000 times of opening and closing).

DE Problem	Erläuterung oder zu ergreifende Maßnahmen
Während der Drehung der Lamellen treten ungewöhnliche Geräusche auf.	Prüfen, ob eine der Lamellen verformt ist. Wenn dies der Fall ist, müssen sie ausgetauscht werden. Wenn die Lamellen nicht verformt sind, aber miteinander kollidieren, den Träger austauschen.
Die Ebenheit der Lamellen ist aufgrund von Witterungseinflüssen beschädigt.	Tauschen Sie die betroffenen Lamellen aus.
Der Abfluss ist durch Laub oder Schutt verstopft.	Reinigen Sie die Kanäle und Dachrinnen der Pergola regelmäßig.
Widerstand gegen Wassereintritt.	Klasse 1 (17 l/m ² pro Stunde).
Mechanische Beständigkeit.	Klasse 1 (6000-maliges Öffnen und Schließen).

EN PROBLEM SOLVING

DE PROBLEMLÖSUNG

FR RÉOLUTION DE PROBLÈMES

NL PROBLEEMOPLOSSING

FR Problème	Explication ou action à entreprendre
Un bruit anormal se produit lors de la rotation de la (des) persiennes.	Vérifiez si l'une des persiennes est déformée. Si c'est le cas, remplacez-les. Si les persiennes ne sont pas déformées mais qu'elles s'entrechoquent, remplacez la poutre.
La planéité de la persienne est endommagée par les conditions climatiques.	Remplacez les persiennes concernées.
L'évacuation est obstruée par des feuilles ou des débris.	Nettoyez régulièrement les conduits et les gouttières de la pergola.
Résistance à l'infiltration d'eau.	Classe 1 (17 l/m ² par heure).
Endurance mécanique.	Classe 1 (6000 cycles d'ouverture et de fermeture).

NL Probleem	Uitleg of te ondernemen actie
Er ontstaat een abnormaal geluid tijdens het draaien van de lamellen.	Controleer of de lamellen vervormd zijn. Vervang ze als dit het geval is. Als de lamellen niet vervormd zijn, maar wel tegen elkaar samenkomen, vervang dan de balk.
Door weersomstandigheden kan de vlakheid van de lamellen beschadigd raken.	Vervang de aangetaste lamellen.
De afvoer is verstopt door bladeren of vuil.	Maak de afvoerkanalen en goten van de pergola regelmatig schoon.
Weerstand tegen ophoping van water.	Klasse 1 (17 l/m ² per uur).
Mechanische duurzaamheid.	Klasse 1 (6000 keer openen en sluiten).

EN CARE & MAINTENANCE

DE PFLEGE UND WARTUNG

FR ENTRETIEN ET MAINTENANCE

NL VERZORGING EN ONDERHOUD



- EN Dust and dirt will collect on the gazebo and will require periodic cleaning.
- DE Staub und Schmutz sammeln sich auf der Pergola und müssen regelmäßig gereinigt werden.
- FR La poussière et la saleté s'accumuleront sur la pergola et devront être nettoyées périodiquement.
- NL Er verzamelt zich stof en vuil op de pergola, waardoor deze regelmatig schoongemaakt moet worden.



- EN Use a water/detergent mixture and a soft clean cloth to clean the gazebo.
- DE Reinigen Sie die Pergola mit einem Wasser-Reinigungsmittel-Gemisch und einem weichen, sauberen Tuch.
- FR Utilisez un mélange d'eau et de détergent et un chiffon doux et propre pour nettoyer la pergola.
- NL Gebruik een mengsel van water en schoonmaakmiddel en een zachte, schone doek om de pergola schoon te maken.



- EN Air dry or wipe with a soft clean cloth.
- DE Lassen Sie sie an der Luft trocknen oder wischen Sie sie mit einem weichen, sauberen Tuch ab.
- FR Séchez à l'air libre ou essuyez avec un chiffon doux et propre.
- NL Laat het aan de lucht drogen of veeg het af met een zachte, schone doek.



- EN For more soiled areas, rinse the surface with clean water from top to bottom.
- DE Bei stärkeren Verschmutzungen spülen Sie die Oberfläche mit sauberem Wasser von oben nach unten ab.
- FR Pour les zones plus sales, rincez la surface à l'eau claire de haut en bas.
- NL Bij hardnekkig vuil spoel het oppervlak van boven naar beneden af met schoon water.



- EN In coastal areas, it is recommended that you frequently spray the gazebo with water to reduce accumulation of salt and dirt.
- DE In Küstengebieten empfiehlt es sich, die Pergola regelmäßig mit Wasser zu besprühen, um die Ansammlung von Salz und Schmutz zu verringern.
- FR Dans les régions côtières, il est recommandé d'arroser fréquemment la pergola avec de l'eau pour réduire l'accumulation de sel et de saleté.
- NL In kustgebieden is het raadzaam om de pergola regelmatig met water te besproeien om ophoping van zout en vuil te voorkomen.

EN CARE & MAINTENANCE

DE PFLEGE UND WARTUNG

FR ENTRETIEN ET MAINTENANCE

NL VERZORGING EN ONDERHOUD



< 0°C / 32°F

- EN When the temperature is below 0°C/32°F, it is recommended to use the product less frequently to prolong the product's service life.
- DE Bei Temperaturen unter 0°C/32°F wird empfohlen, das Produkt weniger häufig zu verwenden, um die Lebensdauer des Produkts zu verlängern.
- FR Lorsque la température est inférieure à 0 °C/32 °F, il est recommandé d'utiliser le produit moins fréquemment afin de prolonger sa durée de vie.
- NL Als de temperatuur lager is dan 0°C/32°F, wordt aanbevolen het product minder vaak te gebruiken om de levensduur ervan te verlengen.



Petroleum based

- EN Do not use any petroleum based spray lubricant.
- DE Verwenden Sie kein Sprühschmiermittel auf Petroleumbasis.
- FR N'utilisez pas de lubrifiant en aérosol à base de pétrole.
- NL Gebruik geen smeermiddel op basis van petroleum.



Silicone based

- EN In most situations it should not be necessary to lubricate the moving components of the gazebo. However, when squeaking occurs, using a silicone spray lubricant is recommended.
- DE In den meisten Situationen sollte es nicht notwendig sein, die beweglichen Teile der Pergola zu schmieren. Wenn jedoch Quietschgeräusche auftreten, wird die Verwendung eines Silikon-Sprühschmiermittels empfohlen.
- FR Dans la plupart des cas, il n'est pas nécessaire de lubrifier les éléments mobiles de la pergola. Toutefois, en cas de grincement, il est recommandé d'utiliser un lubrifiant en aérosol à base de silicone.
- NL In de meeste gevallen is het niet nodig om de bewegende onderdelen van de pergola te smeren. Als er echter sprake is van piepen, is het raadzaam om een siliconenspray als smeermiddel te gebruiken.

EN PERIODIC INSPECTION

- Check the gazebo is fixed firmly to the ground.
- Check that the driving parts are sufficiently lubricated.
- Check the screws and rivet joints on the gazebo.

DE WIEDERKEHRENDE PRÜFUNG

- Prüfen Sie, ob die Pergola fest im Boden verankert ist.
- Prüfen Sie, ob die Antriebssteile ausreichend geschmiert sind.
- Überprüfen Sie die Schrauben und Nietverbindungen an der Pergola.

FR INSPECTION PÉRIODIQUE

- Vérifiez que la pergola est bien fixée au sol.
- Vérifiez que les pièces d'entraînement sont suffisamment lubrifiées.
- Contrôlez les vis et les rivets de la pergola.

NL PERIODIEKE INSPECTIE

- Controleer of de pergola stevig in de grond staat.
- Controleer of de aandrijfonderdelen voldoende gesmeerd zijn.
- Controleer de schroeven en klinknagelverbindingen van de pergola.

PRODUCT WARRANTY & LIMITATION OF LIABILITY

Coolaroo products are manufactured by Gale Pacific Limited ACN 082 263 778 (Gale). Gale provides the following warranty in relation to Coolaroo products ("Product").

The benefits of this warranty are in addition to any rights and remedies imposed by Australian Consumer Law, NZ Consumer Guarantees Act 1993, and state and federal legislation that cannot be excluded. Nothing in this warranty is to be interpreted as excluding, restricting or modifying any applicable legislation to the supply of goods and services which cannot be excluded, restricted or modified.

WARRANTY

Gale warrants that, subject to the exclusions and limitations below, all parts of the manufacture and assembly of the Product will be free from defects in materials and workmanship for a period of three (3) years for the frame from the date of purchase.

If a defect appears in the Product before the end of the warranty period and Gale finds the product to be defective in materials or workmanship, Gale will, in its sole discretion, either:

- a) replace or repair the Product or the defective part of the Product free of charge; or
- b) refund the purchase price of the Product.

Gale reserves the right to replace defective parts of the Product with parts and components of similar quality, grade and composition where an identical part or component is not available.

The warranty will not apply where:

- a) the Product has been altered or modified by someone other than Gale or its authorised agent;
- b) the alleged defect in the Product is within acceptable industry variances;
- c) Gale cannot establish any fault in the Product;
- d) the defect in the Product has arisen due to the customer's failure to install and use the Product in accordance with the instructions provided;
- e) the defect in the Product has arisen due to the customer's request to customise the Product;
- f) the Product has been subject to abnormal conditions, including environment, temperature, water, fire, humidity, pressure, stress or similar.

The warranty does not extend to:

- a) damage or defects caused by normal wear and tear,
- b) water or sun damage; or
- c) any other damage caused by the customer placing other equipment, furniture or material in close proximity to the Product.

Gale makes no express warranties or representations other than set out in this warranty.

The repair or replacement of the Product or part of the Product is the absolute limit of Gale's liability under this express warranty.

WARRANTY CLAIMS

- 1) Upon purchasing the Product, the customer must register their warranty by completing the Coolaroo online warranty registration at www.coolaroo.com. Alternatively, the customer can contact Coolaroo Customer Service on 1800 331 521 (AU) or 0800 555 171 (NZ) for assistance.
- 2) If a fault covered by warranty occurs, the customer must contact Gale using the contact details provided.
- 3) Any warranty claim must be accompanied by proof of purchase and details of the alleged defect.
- 4) The customer must bear the cost of the transport of the Product to and from Gale or the authorised agent to make the warranty claim, and all insurance of the Product.

AUSTRALIAN CONSUMER LAW

Nothing in this agreement is intended to have the effect of contracting out of any applicable provisions of the Competition and Consumer Act 2010 or the Fair Trading Acts in each of the States and Territories of Australia, except to the extent permitted by those Acts where applicable.

This warranty is not transferable, and applies only to the initial purchaser of the installed Product.

In addition to the above warranty, Australian Consumer law and other state and territory legislation may imply warranties or conditions or impose liability on Gale in relation to the Product or its supply which cannot, or can only to a limited implied warranties or conditions and such liability, and for the warranty described above:

- a) all warranties and conditions (whether express or implied, statutory or otherwise) relating to the Product or its supply are expressly excluded; and
- b) Gale will not be liable for any loss or damage suffered by any person (including the purchaser of the Product) in any way relating to or arising from the Product or its use (including loss or damage arising from the negligence of, or contributed to by, Gale).

If liability for breach by Gale of a warranty or condition or any other liability imposed on Gale by legislation which cannot be excluded may be limited, Gale's liability is limited to the extent permitted by law, and if liability may be limited in any one of a number of ways, Gale's liability is limited in any one of the permitted ways chosen by Gale in its absolute discretion.

The Purchaser acknowledges that the Purchaser does not rely on the skill or judgment of Gale as to whether or not the Products are fit for any particular purpose.

The Purchaser indemnifies Gale from every liability, loss, damage, cost or expense directly or indirectly incurred or suffered by Gale caused by or contributed to by the Purchaser's failure to:

- 1) adequately provide or display safety markings or safety information on or with the Products;
- 2) comply with any law about the Products or their use;
- 3) take any reasonable precaution to bring to the attention of any potential users of the Products any dangers associated with Products;
- 4) any negligence or breach of duty by the Purchaser or any breach by the Purchaser of these terms.



THANK YOU
FOR PURCHASING A COOLAROO PRODUCT

Exposure to ultraviolet (UV) radiation from the sun is the major cause of skin cancer. In some countries the UV radiation is strong enough to cause sunburn in just 11 minutes on a fine summers day. To prevent sun damage we recommend following the Sun Smart steps: slip on clothing, slop on sunscreen, slap on a hat, slide on sunglasses and seek shade.

To register your product go to coolaroo.com. The product code can be found printed above the barcode on the product packaging, alternatively you can find it on the relevant coolaroo.com product page.



Gale Pacific Limited
145 Woodlands Drive, Braeside,
Victoria, 3195 Australia

Australia: 1800 331 521
New Zealand: 0800 555 171

2000284

Made in China

© Coolaroo is a registered
trademark of Gale Pacific Limited

coolaroo.com

2025-11